

## OWNER'S MANUAL BEDIENUNGSANLEITUNG



# CPS2.4

# CPS2.6

# CPS2.9

# CPS2.12

CONTRACTOR PRECISION SERIES



**CONTENTS**



**Introduction . . . . . 5**  
 Welcome . . . . . 5  
 Unpacking and Inspection . . . . . 5  
 Scope of Delivery and Warranty . . . . . 5  
 Features and Description . . . . . 5  
 Responsibility of the User . . . . . 5  
**Installation . . . . . 7**  
 Controls, Indicators and Connections . . . . . 7  
 Operating Voltage . . . . . 8  
 Mains Switch . . . . . 8  
 Mounting . . . . . 8  
 Ventilation . . . . . 8  
 Groundlift . . . . . 9  
 High Pass Filter (HPF) . . . . . 9  
 Power on delay . . . . . 9  
 Selecting the Mode Of Operation and Audio Output Cabeling . . . . . 10  
 Audio Input Cabeling . . . . . 11  
**Operation . . . . . 12**  
 Volume Control . . . . . 12  
 Indications . . . . . 12  
 Standby Mode (POWER REMOTE) . . . . . 13  
 Fan Cooling . . . . . 13  
**Options . . . . . 14**  
 RCM-810 . . . . . 14

**INHALT**

**Einführung . . . . . 19**  
 Willkommen . . . . . 19  
 Auspacken und Inspektion . . . . . 19  
 Lieferumfang und Garantie . . . . . 19  
 Eigenschaften & Beschreibung . . . . . 19  
 Verantwortung des Betreibers . . . . . 19  
**Installation . . . . . 20**  
 Bedienelemente, Anzeigen und Anschlüsse . . . . . 20  
 Betriebsspannung . . . . . 21  
 Netzschalter . . . . . 21  
 Einbau . . . . . 21  
 Kühlung . . . . . 21  
 Groundlift . . . . . 22  
 Hochpassfilter (HPF) . . . . . 22  
 Einschaltverzögerung . . . . . 22  
 Betriebsart (MODE) und Verkabelung des Audio-Ausgangs . . . . . 23  
 Verkabelung des Audio-Eingangs . . . . . 24  
**Betrieb . . . . . 25**  
 Eingangspiegel-Regler . . . . . 25  
 Anzeigen . . . . . 25  
 Standby-Modus (POWER REMOTE) . . . . . 26  
 Lüfter . . . . . 26  
**Optionen . . . . . 27**  
 RCM-810 . . . . . 27

**Specifications/Technische Daten . . . . . 30**  
 Mains Operation & Resulting Temperature . . . . . 31  
 Block Diagram / Blockschaltbild . . . . . 33  
 Dimensions / Abmessungen . . . . . 34

## IMPORTANT SAFETY INSTRUCTIONS

	<b>CAUTION</b> RISK OF ELECTRIC SHOCK DO NOT OPEN	
<b>WARNING:</b> TO REDUCE THE RISK OF FIRE OR ELECTRIC SHOCK, DO NOT EXPOSE THIS APPLIANCE TO RAIN OR MOISTURE. <b>AVIS:</b> RISQUÉ DE CHOC ELECTRIQUE, NE PAS OUVRIR.		
<b>WARNING:</b> CONNECT ONLY TO MAINS SOCKET WITH PROTECTIVE EARTHING CONNECTION.		



The lightning flash with arrowhead symbol, within an equilateral triangle is intended to alert the user to the presence of uninsulated „dangerous voltage“ within the product's enclosure that may be of sufficient magnitude to constitute a risk of electric shock to persons.



The exclamation point within an equilateral triangle is intended to alert the user to the presence of important operating and maintenance (servicing) instructions in the literature accompanying the appliance.

1. Read these instructions.
2. Keep these instructions.
3. Heed all warnings.
4. Follow all instructions.
5. Do not use this apparatus near water.
6. Clean only with a dry cloth.
7. Do not cover any ventilation openings. Install in accordance with the manufacturer's instructions.
8. Do not install near heat sources such as radiators, heat registers, stoves, or other apparatus (including amplifiers) that produce heat.
9. Do not defeat the safety purpose of the polarized or the grounding-type plug. A polarized plug has two blades with one wider than the other. A grounding type plug has two blades and a third grounding prong. The wide blade or the third prong are provided for your safety. If the provided plug does not fit into your outlet, consult an electrician for replacement of the obsolete outlet.
10. Protect the power cord from being walked on or pinched particularly at plugs, convenience receptacles, and the point where they exit from the apparatus.
11. Only use attachments/accessories specified by the manufacturer.
12. Use only with the cart, tripod, bracket, or table specified by the manufacturer, or sold with the apparatus. When a cart is used, use caution when moving the cart/apparatus combination to avoid injury from tip-over.



13. Unplug this apparatus during lightning storms or when unused for a long period of time.
14. Refer all servicing to qualified service personnel. Servicing is required when the apparatus has been damaged in any way, such as power-supply cord or plug is damaged, liquid has been spilled or objects have fallen into the apparatus, the apparatus has been exposed to rain or moisture, does not operate normally, or has been dropped.
15. Do not expose this equipment to dripping or splashing and ensure that no objects filled with liquids, such as vases, are placed on the equipment.
16. To completely disconnect this equipment from the AC Mains, disconnect the power supply cord plug from the AC receptacle.
17. The mains plug of the power supply cord shall remain readily operable.

## IMPORTANT SERVICE INSTRUCTIONS

**CAUTION:** These servicing instructions are for use by qualified personnel only. To reduce the risk of electric shock, do not perform any servicing other than that contained in the Operating Instructions unless you are qualified to do so. Refer all servicing to qualified service personnel.

1. Security regulations as stated in the EN 60065 (VDE 0860 / IEC 65) and the CSA E65 - 94 have to be obeyed when servicing the appliance.
2. Use of a mains separator transformer is mandatory during maintenance while the appliance is opened, needs to be operated and is connected to the mains.
3. Switch off the power before retrofitting any extensions, changing the mains voltage or the output voltage.
4. The minimum distance between parts carrying mains voltage and any accessible metal piece (metal enclosure), respectively between the mains poles has to be 3 mm and needs to be minded at all times. The minimum distance between parts carrying mains voltage and any switches or breakers that are not connected to the mains (secondary parts) has to be 6 mm and needs to be minded at all times.
5. Replacing special components that are marked in the circuit diagram using the security symbol (Note) is only permissible when using original parts.
6. Altering the circuitry without prior consent or advice is not legitimate.
7. Any work security regulations that are applicable at the locations where the appliance is being serviced have to be strictly obeyed. This applies also to any regulations about the work place itself.
8. All instructions concerning the handling of MOS-circuits have to be observed.

**NOTE:**



**SAFETY COMPONENT (MUST BE REPLACED BY ORIGINAL PART)**

## WEEE RECYCLING/DISPOSAL INSTRUCTIONS



**FOR RECYCLING  
INFORMATION  
CONTACT YOUR  
DISTRIBUTOR OR  
VISIT OUR WEBSITE**

**WWW.EVIAUDIO.COM**

The Wheelie Bin symbol found on the product or in the manual indicates that this product must not be disposed of with other waste. It is in our category the manufacturer's responsibility to properly dispose of their waste electrical and electronic equipment (WEEE) at the end of its life. Due to the differences in each EU country's management of WEEE, please contact your local distributor. We are committed to facilitate our own electronic-waste-management-system, for the free of charge return of all EVI Audio GmbH products: Telex, Dynacord, ElectroVoice, Midas Consoles, KlarkTeknik and RTS. Arrangements are made with the dealer where you purchased the equipment from, for the returning of all unusable equipment **at no cost**, to the factory in Straubing, for environmental protective disposal.

## 1 Introduction

### 1.1 Welcome

Thank you for choosing an Electro-Voice CPS series amplifier. Please take time to consult this manual so that you can understand all the features built into your Electro-Voice amplifier and fully utilize all its performance capabilities.

### 1.2 Unpacking and Inspection

Carefully open the packaging and take out the power amplifier. Inspect the power amp's enclosure for damages that might have happened during transportation. Each amplifier is examined and tested in detail before leaving the manufacturing site to ensure that it arrives in perfect condition at your place. Please inform the transport company immediately, if the power amplifier shows any damage. Being the addressee, you are the only person who can claim damages in transit. Keep the cardboard box and all packaging materials for inspection by the transport company.

Keeping the cardboard box including all packing materials is also recommended, if the power amplifier shows no external damages.

#### **CAUTION:**

**Do not ship the power amp in any other but its original packaging.**

When shipping the power amp, make sure to always use its original box and packaging materials. Packing the power amplifier like it was packed by the manufacturer guarantees optimum protection from transport damage.

### 1.3 Scope of Delivery and Warranty

- 1 Power Amplifier
- 1 Owner's Manual (this document)
- 1 Mains Cord
- 1 Output connector, 4 pole
- 2 Input connector, 3 pole
- 1 Power Remote connector, 2 pole
- 1 Warranty Certificate

Keep the original invoice that states the purchase/delivery date together with the warranty certificate at a safe place.

### 1.4 Features and Description

Electro-Voice CONTRACTOR PRECISION SERIES Series amplifiers offer a package of reliable high output power, high efficiency and legendary pro audio performance. They are the premium choice as system drive for a variety of Electro-Voice's installation loudspeakers like e.g. EVI, FRI, FRX or Variplex families. Their comprehensive protection system includes circuitry against overheating, overload, short circuit, HF and DC as well as back-EMF and inrush current. Loudspeakers are protected by turn-on-delay relays.

### 1.5 Responsibility of the User

#### **Speaker System Damage**

CPS power amps provide extremely high power output that might be dangerous for human beings as well as for the connected speaker systems. High output voltages can damage or even destroy the connected speaker systems, especially, when the CPS amplifier is operated in bridged mode. Prior to connecting any loudspeakers, make sure to check the speaker system's specifications for continuous and peak power handling capacities. Even if amplification has been reduced through lowering the input level controls on the amplifier's front panel, it is still possible to achieve full power output with a sufficiently high input signal.

#### **Danger at the Loudspeaker/Power Outputs**

CPS amplifiers are capable of producing dangerously high voltage output that is present at the output connectors. To protect yourself from electric shock, do not touch any blank speaker cables during operation of the power amp.

**WARNING:**

**The terminals marked with ⚡ are hazardous live and the external wiring connected to these terminals requires installation by an instructed person or the use of ready-made leads of cords.**

**HF-Interference (FCC Information USA)**

1. IMPORTANT: Do not modify this unit! Changes or modifications not expressly approved by the manufacturer could void the user's authority, granted by the FCC, to operate the equipment.

2. NOTE: This equipment has been tested and found to comply with the limits for a Class A digital device, pursuant to Part 15 of the FCC Rules. These limits are designed to provide reasonable protection against harmful interference in a residential installation. This equipment generates, uses and can radiate radio frequency energy and, if not installed and used in accordance with the instructions, may cause harmful interference to radio communications. However, there is no guarantee that interference will not occur in a particular installation. If this equipment does cause harmful interference to radio or television reception, which can be

determined by turning the equipment off and on, the user is encouraged to try to correct the interference by one or more of the following measures:

- Reorient or relocate the receiving antenna
- Increase the separation between the equipment and receiver
- Connect the equipment into an outlet on a circuit different from that to which the receiver is connected
- Consult the dealer or an experienced radio/TV technician for help

**This is a Class A product. In a domestic environment this product may cause radio interferences in which case the user may be required to take adequate measures.**

This Class A digital apparatus complies with Canadian ICES-003.  
Cat appareil numérique de la classe A est conforme à la norme NMB-003 du Canada.

## 2 Installation

### 2.1 Controls, Indicators and Connections

#### Front View

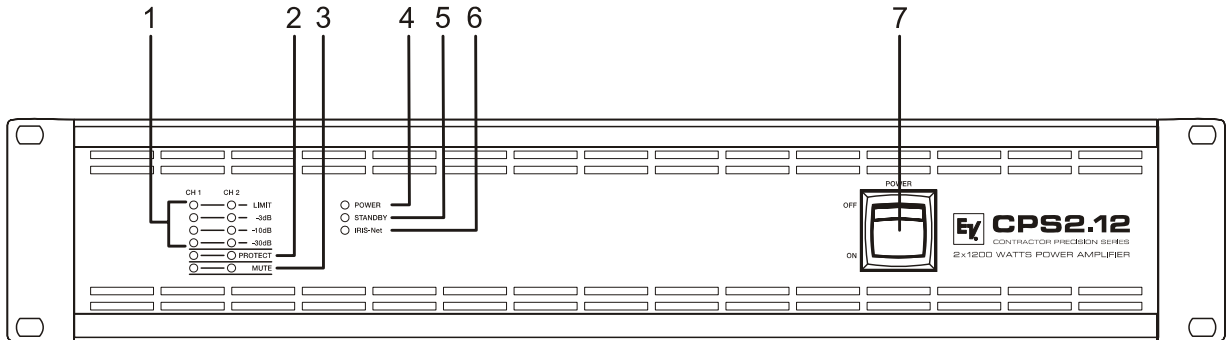

- 1 Level Indicators for channels 1 and 2
- 2 Protections Indicator (PROTECT)
- 3 Muting Indicator (MUTE) for channels 1 and 2
- 4 Power On/Off Indicator (POWER)
- 5 Standby Indicator (STANDBY)
- 6 Remote Amplifier Indicator (IRIS-Net)
- 7 Mains Switch

#### Rear View

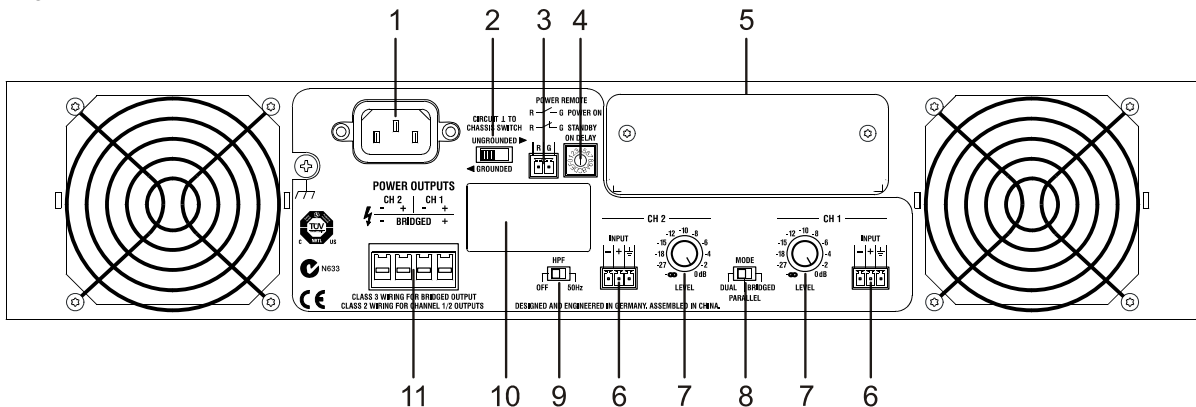

- 1 Mains Input
- 2 Ground Lift Switch (CIRCUIT ⊥ TO CHASSIS SWITCH)
- 3 POWER REMOTE connector
- 4 Power On Delay selection switch (ON DELAY)
- 5 Expansion Slot
- 6 Audio Inputs (INPUT) for channels 1 and 2
- 7 Input Level Control (LEVEL) for channels 1 and 2
- 8 Power Amp Mode Switch (MODE)
- 9 Highpass Filter Switch (HPF)
- 10 Type Plate
- 11 Power Amp Outputs (CH 1, CH 2, BRIDGED)

## 2.2 Operating Voltage

The power amplifier receives its power supply via the MAINS IN connector. Only the provided power cord may be used. During installation, always separate the power amplifier from the mains. Connect the power amplifier only to a mains network, which corresponds to the requirements indicated on the type plate.

## Mains Operation & Resulting Temperature

The power drawn from the mains network is converted into output power to feed the connected loudspeaker systems and into heat. The difference between power consumption and dispensed power is called power dissipation ( $P_d$ ). The amount of heat resulting from power dissipation might remain inside of a rack-shelf and needs to be diverted using appropriate measures. The tables on page 31 allow the determination of power supply and cabling requirements. The tables are meant as auxiliary means for calculating temperatures inside of a rack-shelf system/cabinet and the ventilation efforts necessary.

The column  $P_d$  lists the leakage power in relation to different operational states. The column BTU/hr lists the dispensed heat amount per hour. Power consumption is direct proportional for other mains voltages. The following conversion factors are meant for easy conversion: 100V = 2.3; 120V = 1.9; 240V = 0.96

## 2.3 Mains Switch

The Mains Switch on the front panel separates the power amp from the mains. Turning the Mains Switch to ON starts booting up the power amp. A soft start circuit compensates mains inrush current peaks and thus prevents triggering AC mains fuse when switching on the amplifier. Speaker system switch-on is delayed by approximately 2 seconds via output relays, effectively suppressing any possible power-on noise, which otherwise might be heard through the loudspeakers. PROTECT-LED light and fans are at high speed during this delay. This indicates all protections are working fine.

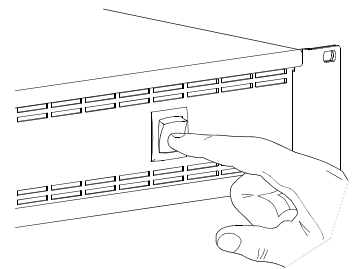

## 2.4 Mounting

CPS amplifiers have been designed for installation in a conventional 19-inch rack case. Attach the power amp with its frontal rack mount ears using 4 screws and washers as shown in following illustration.

Additionally securing the amplifier at the rear becomes necessary, if the rack case in which the power amplifier has been installed will be transported. Failure to do so may result in damage to the power amplifier as well as to the rack case. Attach the power amp as shown in the illustration using 4 case nuts and screws. Brackets for securing the power amplifier are available as accessories.

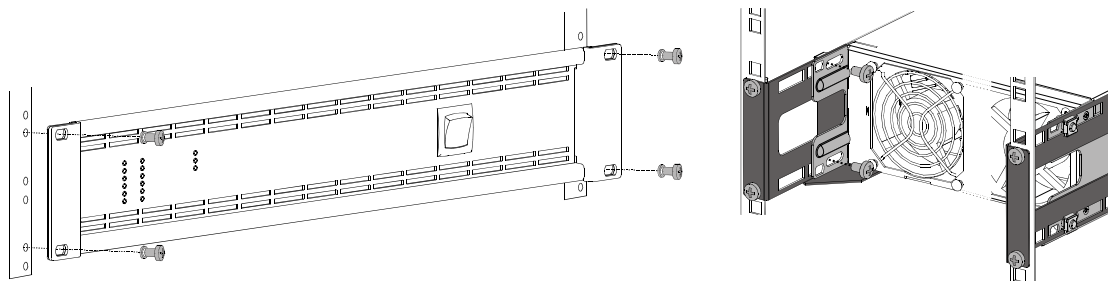

## 2.5 Ventilation

As with all Electro-Voice power amps with fan cooling, the airflow direction is front-to-rear, obviously because there is more cold air outside of the rack case than inside. The power amplifier remains cooler and dissipating the developing waste heat in a specific direction gets easier. In general, setting up or mounting the power amplifier has to be done in a way that fresh air can enter unhindered at the front and exhausted air can exit at the rear. When installing the power amp in a case or rack system, attention should be paid to these details to provide sufficient ventilation. Allow for an air duct of at least 60 mm x 330 mm between the rear panel of the power amplifier and the inner wall of the cabinet/rack case. Make sure that the duct reaches up to the cabinet's or the rack case's top ventilation louvers. Leave room of at least 100 mm above the cabinet/rack case for ventilation. Since temperatures inside of the cabinet/rack case can easily rise up to 40 °C during operation of the power amp, it is mandatory to bear in mind the maximum allowable ambient temperature for all other appliances installed in the same cabinet/rack case.

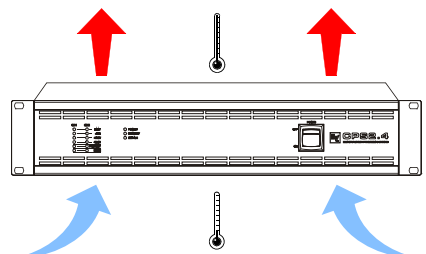

**CAUTION:**

**Blocking/closing the power amp’s ventilation louvers is not permissible. Without sufficient cooling/ventilation, the power amplifier may automatically enter protect mode. Keep ventilation louvers free from dust to ensure unhindered airflow.**

**Do not use the power amplifier near heat sources, like heater blowers, stoves or any other heat radiating devices.**

**To ensure trouble-free operation, make certain that the maximum allowable ambient temperature of +40°C is not exceeded.**

For fixed amplifier installations in a device control room that incorporate a central air-cooling system or air conditioners, calculating the maximum heat emission may be necessary. Please also take notice of the information on page 31.

**2.6 Groundlift**

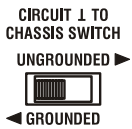

The ground lift switch allows eliminating noise loops. When operating the power amplifier together with other equipment in a rack case, setting the switch to the GROUNDED position is recommended. Set the switch to UNGROUNDED, when the power amplifier is operated together with appliances with differing ground potentials.

**2.7 High Pass Filter (HPF)**

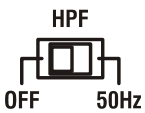

The Hi-Pass filter (50 Hz, 18 dB/oct) allows effective attenuation of low frequency audio signals, which could cause saturation problems with connected output transformers. Set the switch to the 50Hz position for activating the High Pass Filter. Set the switch to the OFF position if no attenuation of low frequency audio signals is required.

**2.8 Power on delay**



The ON DELAY switch at the amplifier rear panel allows selecting the power on delay time. Following table shows possible switch settings and corresponding delay times.

ON DELAY	Delay time (in s)
0	0.52
1	0.59
2	0.63
3	0.69
4	0.75
5	0.84
6	0.90
7	0.95

ON DELAY	Delay time (in s)
8	1.05
9	1.15
A	1.25
B	1.40
C	1.49
D	1.55
E	1.61
F	1.69

## 2.9 Selecting the Mode Of Operation and Audio Output Cabeling

The MODE switch on the power amp's rear panel defines how the audio inputs handle the input signals. Possible settings are DUAL, PARALLEL or BRIDGED.

### DUAL

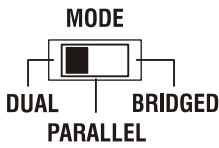

In DUAL mode, the two channels of the power amplifier work independent from each other. This mode of operation is being used for all 2-channel applications, like stereo operation. Using the input level controls on the power amp's rear panel allows independently adjusting the channels' amplification.

### PARALLEL

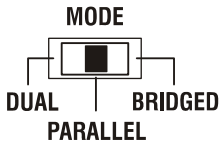

In PARALLEL mode, the inputs of channel 1 and channel 2 are directly electrically linked. The audio signal has to be applied to the input connectors of channel 1. Using the input level controls to independently control the amplification of the two channels is still possible because only the channels' inputs are linked. PARALLEL operation is the mode of choice, whenever the same input signal drives multiple power amp channels of a large system installation.

### CAUTION:

**In PARALLEL mode, the input signal has to be fed to input channel 1 only.**

See illustration right for connecting speakers in DUAL or PARALLEL mode. The correct connection is also indicated at the amplifiers rear panel.

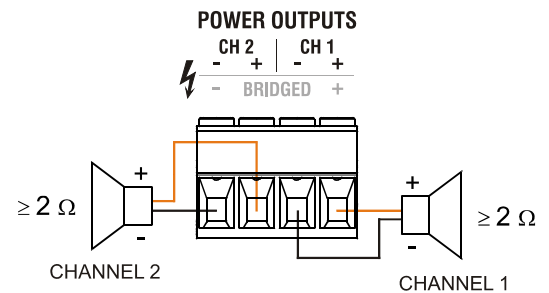

### BRIDGED

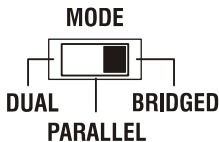

In BRIDGED mode both amp channels work in push-pull operation to provide doubled output voltage. The audio signal has to be applied to the input connectors of channel 1, amplification is set via input level control of channel 1 only.

### CAUTION:

**In BRIDGED mode, the input signal has to be fed to input channel 1 only. Amplification is set via input level control of channel 1 only.**

**In BRIDGED mode operation, it is not allowable for the load connected to fall below a value of 4 ohms. Extremely high voltages can be present at the output. The connected speaker systems must be able to handle such voltages. Make sure to completely read and fully observe power rating specifications of the speaker systems to be used and to check them against the output power capacity of the power amp.**

Setting the MODE switch on the power amp's rear panel to BRIDGED lets the power amplifier run in bridged mode operation and speaker connection has to be established using pins 1+ and 2-, see illustration right. The correct connection is also indicated at the amplifiers rear panel.

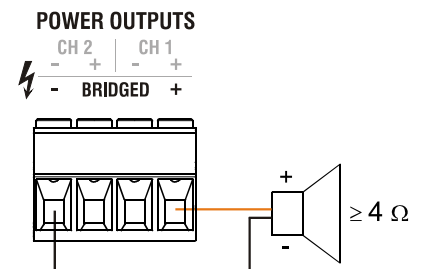

## 2.10 Audio Input Cabeling



Inputs are electronically balanced. Whenever possible, using balanced audio signal feeds at the input of the power amplifier is always preferred. Unbalanced connections should only be used if the cables are very short and no interfering signals are to be expected in the vicinity of the power amplifier. In this case, bridging the screen (shielding) and the pin of the inverting input inside of the connector is mandatory. Otherwise, a 6 dB drop in level could result. Please also see following illustration. Due to their immunity against external interference sources, such as dimmers, mains connections, HF-control lines, etc., using balanced cabling and connections is always preferable.



Illustration 2.1: Balanced / unbalanced connection of input

## 3 Operation

### 3.1 Volume Control

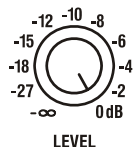

In DUAL and PARALLEL mode, the level controls LEVEL on the power amp's rear panel are used to control the amplification of the corresponding channel. Turning the control to the right increases and turning it to the left decreases the volume. In BRIDGED mode operation, the output volume of the power amp is only controlled by the CH 1 level control. Any changes in the setting of the CH 2 level control are ignored.

### 3.2 Indications

#### PROTECT

- PROTECT      The PROTECT LED lights indicating that one of the internal protection circuits against thermal overload, short-circuit, Back-EMF, HF-occurrence at the output, etc., has been activated. In that case, the output relays separate the power amps from the load connected to prevent the connected loudspeaker systems and the power amplifiers as well from being damaged. Whatever caused the fault – e.g. a short-circuited speaker cable – needs to be remedied. In case of thermal overload you have to wait until the power amplifier automatically regains normal operation.

#### MUTE

- MUTE      The MUTE LED lights red whenever the power amp's output signal is being muted, which happens when manually muting the output signal via IRIS-Net™.

#### -30dB...LIMIT

- LIMIT      Level indication is realized via vertical LED chains on the power amp's front panel that individually indicate the actual levels of each channel at -30dB, -10dB and -3dB below full modulation. The LIMIT LED lights as soon as the integrated dynamic audio limiter is activated and the power amplifier is driven at the clipping limit or generally at its maximum capacity. Short-term blinking is not a problem, because the internal limiter controls input levels of up to +21 dBu down to a THD of approximately 1 %. If, on the other hand, the LIMIT LED light constantly, reducing the volume is recommended to prevent the loudspeaker systems connected from being damaged by probable overload.
- -3dB
- -10dB
- -30dB

#### POWER

- POWER      The POWER LED lights green when the power amplifier is on. If the POWER-LED does not light, despite the fact that the amplifier has been switched on, this indicates that the power amp is not connected to the mains or the primary fuse has blown.

#### STANDBY

- STANDBY      The STANDBY-LED lights yellow when the power amp is in standby mode. Standby mode reduces the amp's power consumption to an absolute minimum. Activating the standby mode is possible via IRISNet™ or the POWER REMOTE port at the amp's rear panel.

#### IRIS-Net

- IRIS-Net      The IRIS-Net-LED lights blue if an IRIS-Net™-compatible remote control module has been installed in the power amp's extension slot and successful data communication has been established. The IRIS-Net LED blink slowly whenever the "Find" function in IRIS-Net™ is being used to locate a power amplifier in the rack.

### 3.3 Standby Mode (POWER REMOTE)

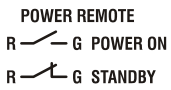

POWER REMOTE provides a simple way to remotely power-on/off the power amplifier. The POWER REMOTE function is only useful for appliances not employing a Remote Control Modul. Controlling CPS amplifiers with Remote Control Module installed per POWER REMOTE is not recommended.

Leaving the pins of POWER REMOTE socket open the appliance power is switched on. When connecting the pins the appliance enters standby mode.

### 3.4 Fan Cooling

The power amplifier has two fans. The fans are switched in three performance-optimized levels, i.e. they are not running permanently but the speed of the fans is controlled depending on the temperature. That in return ensures very silent running during idle state.

The temperatures of the power amps's channels are registered and monitored individually.

## 4 Options

Installing one of the optionally available extension modules in the extension slot on the rear panel lets you expand the power amp’s functional range. As an example, the following paragraphs describe the RCM-810 Remote Control Module. Please read and follow the instructions provided in the documentation that you have received together with each extension module.

### 4.1 RCM-810

#### System Description and Features

The RCM-810 Remote Control Module is a digital controller module for live sound reinforcement, PA and fixed installation applications. Installing the RCM-810 turns a conventional amp into a remote amplifier, which, at any time, provides complete overview of the overall system status and control of all system parameters.

RCM-810 modules allow the integration of amplifiers into a remote control network with up to 250 units. This offers the possibility to control and monitor an entire PA system from one or more PCs using the IRIS-Net - Intelligent Remote & Integrated Supervision - software package. All operational states, e.g. power-on status, temperature, activation of protections, load impedance, etc., are centrally registered and displayed in IRIS-Net. This provides the possibility to react and to selectively intervene even before critical operational states arise. Programming an automatic reaction, when specific thresholds are being exceeded or fallen below, is also possible.

All parameters, like power on/off, muting, etc. can be controlled in real-time and stored in the amplifier. In the event of network failure or loss of power, all settings stay intact, independent of the control by the network.

Furthermore, the RCM-810 provides a control port with freely programmable control inputs and control outputs. Control inputs (GPI's) allow the connection of switches. IRIS-Net offers the possibility to program a variety of logic functions for the inputs. Control outputs (GPO's) allow the connection of external components, which, for example, are used to signal specific states to peripheral equipment. Consequently, an amplifier with a RCM-810 module installed corresponds to highest safety requirements. For further details about configuration, control and monitoring of amps with installed RCM-810 modules, please refer to the documentation of the IRIS-Net. The latest version of IRIS-Net is available at [www.electrovoice.com](http://www.electrovoice.com).



#### Controls and Connections

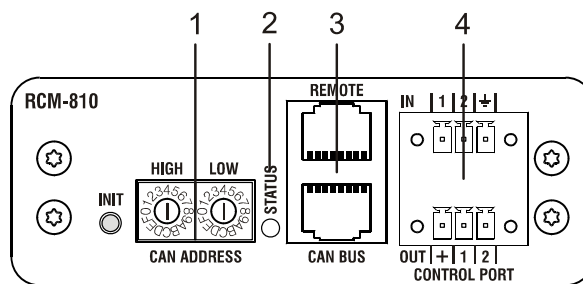
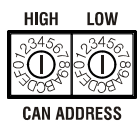

Illustration 4.1: Controls and Connections of the RCM-810

#### 1 ADDRESS Selector Switch



The two address selector switches are for setting the network address of the RCM-810. CAN networks support addresses in the range of 01 to 250 (FA hex). Addressing has to be carried out in the hexadecimal number system. The LOW selector switch sets the lower digit, while HIGH sets the higher digit.

#### CAUTION:

**Each address may exist only once in a system. Otherwise, network conflicts may arise.**

HIGH	LOW	Address
0	0	Stand-alone
0	1...F	1...15
1	0...F	16...31
2	0...F	32...47
3	0...F	48...63
4	0...F	64...79
5	0...F	80...95
6	0...F	96...111
7	0...F	112...127

HIGH	LOW	Address
8	0...F	128...143
9	0...F	144...159
A	0...F	160...175
B	0...F	176...191
C	0...F	192...207
D	0...F	208...223
E	0...F	224...239
F	0...A	240...250
F	B...F	reserved

Table 4.1: CAN addresses

Address 0 (00 hex, delivery status) disables remote communication between the RCM-810 and the bus. The module does not appear in the system, even though it is physically connected to the CAN-bus.

**2 STATUS LED**

○ STATUS

The STATUS-LED is for monitoring the communication on the CAN bus. The LED blinks rhythmically every 3 seconds, when the module’s address is set to “00“, which means that it is disconnected from the CAN bus and software control. The LED blinks rhythmically in intervals of one second, when an address in the range of 01 to 250 has been assigned to the module and there has not yet been any activity on the CAN bus. As soon as communication on the CAN bus is recognized, the LED lights for at least 100 ms, when the power amplifier sends data on the CAN bus.

**3 REMOTE CAN BUS Connection**

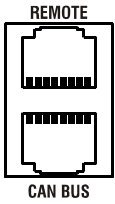

The RCM-810 module provides two RJ-45 sockets for connecting to the REMOTE CAN BUS. These sockets are connected in parallel and serve as inputs as well as for daisy-chaining the devices on the remote network. Cabling in a rack system can be established using commercially available RJ-45 network cables. However, CAN guidelines have to be observed for longer cable lengths. Both ends of the CAN-bus must be terminated using 120 Ω terminating plugs.

The CAN bus allows using different data rates, whereas the data rate is inversely proportional to the bus length. For smaller network setups, data rates can be as high as 500 kbit/s. For broader networks, reducing the data rate becomes necessary (down to the minimum data rate of 10 kbit/s).

**NOTE:**

**The data rate of the CAN bus is preset to 10 kbit/s.**

The following table illustrates the relation between data rate and bus length or network size. The use of CAN repeaters is strongly recommended for busses that exceed 1000 meters in length.

Transfer rate (in kbit/s)	Bus length (in m)
500	100
250	250
125	500
62,5	1000
20	2500
10	5000

Table 4.2: Transfer rate and bus length

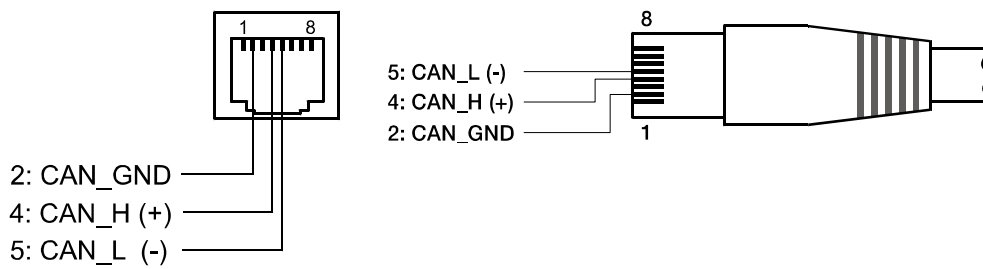
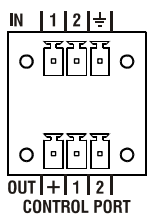

Illustration 4.2: Pin-assignment of CAN jack and CAN plug

Pin	Name	Colour	
		T568A	T568B
2	CAN_GND	Green	Orange
4	CAN_H (+)	Blue	
5	CAN_L (-)	Blue striped	

Table 4.3: Overview CAN plug

**4 CONTROL PORT**



The CONTROL PORT of the RCM-810 provides two control inputs, two control outputs and reference connections for +5V and ground. The control inputs are configurable via IRIS-Net™. They can be used for example for switching between power on / standby modes. The two control contacts IN1 and IN2 are internally connected via pull-up resistors and carry +5V (open). The control inputs can be activated using external switches, pushbuttons or relays to connect them to ground potential (pin 3). The two control outputs OUT1 and OUT2 are open collector outputs, which are highly resistive in the non-active state (off). In active state (on) the outputs are connected to ground. The control outputs are configurable via IRIS-Net™ and are used to signal internal states. LEDs, indicators or relays can be driven directly. The +5V reference connector provides voltage supply for connected components.

**CAUTION:**

**The maximally allowable current at the +5V output is 200 mA.**

**System Example**

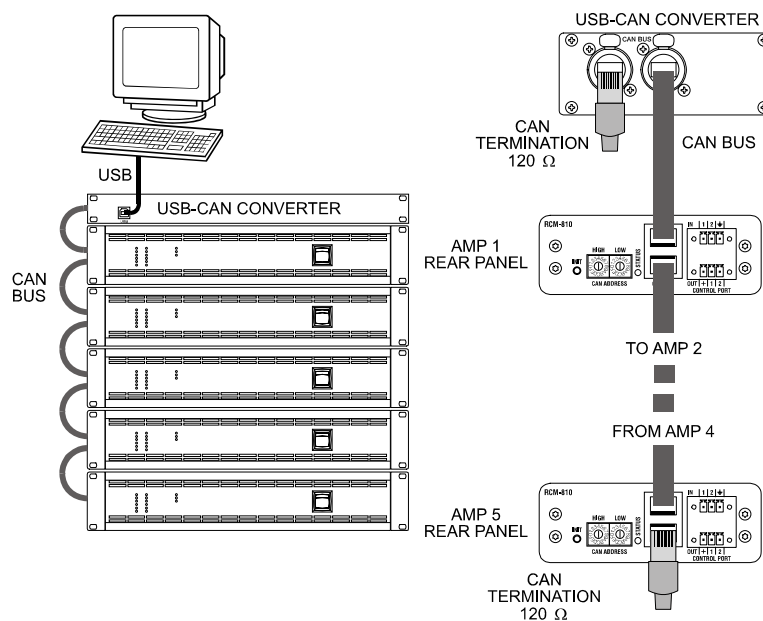



## Specifications/Technische Daten

Amplifier at rated conditions, both channels driven, 8 Ω load, unless otherwise specified.

	CPS2.4			CPS2.6			CPS2.9			CPS2.12		
Load Impedance	2 Ω	4 Ω	8 Ω	2 Ω	4 Ω	8 Ω	2 Ω	4 Ω	8 Ω	2 Ω	4 Ω	8 Ω
<b>Maximum Midband Output Power</b> THD = 1%, 1 kHz, Dual Channel	650 W	450 W	270 W	900 W	600 W	380 W	1250 W	900 W	550 W	1800 W	1200 W	750 W
<b>Rated Output Power</b> THD < 0.1%, 20 Hz...20 kHz	-	400 W	200 W	-	500 W	250 W	-	800 W	400 W	-	1100 W	550 W
<b>Maximum Single Channel Output Power</b> Dynamic-Headroom, IHF-A	1150 W	660 W	350 W	1700 W	950 W	480 W	2450 W	1400 W	700 W	3400 W	1800 W	950 W
<b>Maximum Single Channel Output Power</b> Continuous, 1 kHz	850 W	540 W	310 W	1200 W	750 W	420 W	1700 W	1100 W	630 W	2400 W	1500 W	850 W
<b>Maximum Bridged Output Power</b> THD = 1%, 1 kHz	-	1300 W	900 W	-	1800 W	1200 W	-	2800 W	1800 W	-	3600 W	2400 W
<b>Maximum RMS Voltage Swing</b> THD = 1%, 1 kHz	55.3 V			65.1 V			78.8 V			90.6 V		
<b>Power Bandwidth</b> THD = 1%, ref. 1 kHz, half power @ 4 Ω	< 10 Hz...30 kHz											
<b>Voltage Gain</b> , ref. 1 kHz	32.0 dB											
<b>Input Sensitivity</b> rated power @ 8 Ω, 1 kHz	+2.2 dBu (1.0 V <sub>rms</sub> )			+3.1 dBu (1.11 V <sub>rms</sub> )			+5.1 dBu (1.39 V <sub>rms</sub> )			+6.6 dBu (1.66 V <sub>rms</sub> )		
<b>THD at rated output power</b> MBW = 80 kHz, 1 kHz	< 0.03%											
<b>IMD-SMPTE</b> , 60 Hz, 7 kHz	< 0.1%											
<b>DIM30</b> , 3.15 kHz, 15 kHz	< 0.05%											
<b>Maximum Input Level</b>	+21 dBu (8.69 V <sub>rms</sub> )											
<b>Crosstalk</b> ref. 1 kHz, at rated output power	< -80 dB											
<b>Frequency Response</b> , ref. 1 kHz	10 Hz...40 kHz (±1 dB)											
<b>Input Impedance</b> , active balanced	20 kΩ											
<b>Damping Factor</b> , 1 kHz	> 300											
<b>Slew Rate</b>	25 V/μs			26 V/μs			27 V/μs			30 V/μs		
<b>Signal to Noise Ratio Amplifier</b> A-weighted	> 106 dB			> 107 dB			> 109 dB			> 110 dB		
<b>Output Noise</b> , A-weighted	< -71 dBu											
<b>Output Stage Topology</b>	Class AB						Class H					
<b>Power Requirements</b>	240 V, 230 V, 120 V or 100 V; 50 Hz...60 Hz (factory configured)											
<b>Power Consumption</b> 1/8 maximum output power @ 4 Ω	550 W			700 W			700 W			850 W		
<b>Mains Fuse</b>	240 V / 230 V: T10AH; 120 V / 100 V: T20AH			240 V / 230 V: T12AH; 120 V / 100 V: T25AH			240 V / 230 V: T15AH; 120 V / 100 V: T25AH			240 V / 230 V: T15AH; 120 V / 100 V: T30AH		
<b>Protection</b>	Audio limiters, High temperature, DC, HF, Back-EMF, Peak current limiters, Inrush current limiters, Turn-on delay											
<b>Cooling</b>	Front-to-rear, 3-stage-fans											
<b>Ambient Temperatur Limits</b>	+5 °C...+40 °C (40 °F...105 °F)											
<b>Safety Class</b>	I											
<b>Dimensions</b> (W x H x D), mm	483 x 88.1 x 421.5											
<b>Weight</b>	12.6 kg (27.8 lbs)			14.8 kg (32.6 lbs)			16.3 kg (35.9 lbs)			17.7 kg (39.0 lbs)		
<b>Signal Processing</b>	Lo-Cut 50 Hz / 18 dB, switchable											
<b>Optional</b>	2-Way crossover, internal filter card, 24 dB, LR 500 Hz (NRS 90250), 800 Hz (NRS 90251)											

Depending on the ambient temperature, the unit might not operate continuously at 2 Ω load in Dual Mode or 4 Ω in Bridged Mode.  
In addition input power exceeds 1.1 times rated power consumption with 2 Ω load in Dual Mode or 4 Ω load in Bridged Mode

### 5.1 Mains Operation & Resulting Temperature

CPS2.4	U <sub>mains</sub> in V	I <sub>mains</sub> in A	P <sub>mains</sub> in W	P <sub>out</sub> in W	P <sub>d</sub> in W <sup>1</sup>	BTU/hr <sup>2</sup>
Idle	230	0.3	38	0	38	130
Max. Output Power @ 8 Ω <sup>3</sup>	230	4.9	800	540	260	887
Max. Output Power @ 4 Ω <sup>3</sup>	230	8.0	1450	900	550	1877
1/3 Max. Output Power @ 4 Ω <sup>3</sup>	230	5.1	900	300	600	2047
1/8 Max. Output Power @ 4 Ω <sup>3</sup>	230	3.4	550	112.5	437.5	1493
1/8 Max. Output Power @ 4 Ω <sup>4</sup>	230	3.0	470	112.5	357.5	1220
1/8 Max. Output Power @ 4 Ω <sup>4.5</sup>	253	3.2	560	135	425	1450
Normal Mode (-10 dB) @ 4 Ω <sup>3</sup>	230	3.0	450	80	370	1262
Rated Output Power (0 dB) @ 4 Ω <sup>3</sup>	230	7.6	1380	800	580	1979
Alert (Alarm) Mode (-3 dB) @ 4 Ω <sup>3</sup>	230	5.7	1000	400	600	2047
Max. Output Power @ 2 Ω <sup>3</sup>	230	12.1	2250	1300	950	3242
1/8 Max. Output Power @ 2 Ω <sup>3</sup>	230	5.2	900	162.5	737.5	2516
1/8 Max. Output Power @ 2 Ω <sup>4</sup>	230	4.8	750	162.5	587.5	2005

CPS2.6	U <sub>mains</sub> in V	I <sub>mains</sub> in A	P <sub>mains</sub> in W	P <sub>out</sub> in W	P <sub>d</sub> in W <sup>1</sup>	BTU/hr <sup>2</sup>
Idle	230	0.4	46	0	46	157
Max. Output Power @ 8 Ω <sup>3</sup>	230	6.7	1110	760	350	1194
Max. Output Power @ 4 Ω <sup>3</sup>	230	10.8	1970	1200	770	2627
1/3 Max. Output Power @ 4 Ω <sup>3</sup>	230	6.9	1150	400	750	2559
1/8 Max. Output Power @ 4 Ω <sup>3</sup>	230	4.6	740	150	590	2013
1/8 Max. Output Power @ 4 Ω <sup>4</sup>	230	4.0	630	150	480	1638
1/8 Max. Output Power @ 4 Ω <sup>4.5</sup>	253	4.5	760	190	570	1945
Normal Mode (-10 dB) @ 4 Ω <sup>3</sup>	230	3.9	610	100	510	1740
Rated Output Power (0 dB) @ 4 Ω <sup>3</sup>	230	10.0	1800	1000	800	2730
Alert (Alarm) Mode (-3 dB) @ 4 Ω <sup>3</sup>	230	7.5	1320	500	820	2798
Max. Output Power @ 2 Ω <sup>3</sup>	230	16.6	3260	1800	1460	4982
1/8 Max. Output Power @ 2 Ω <sup>3</sup>	230	7.1	1160	225	935	3190
1/8 Max. Output Power @ 2 Ω <sup>4</sup>	230	6.2	1040	225	815	2781

Power consumption is direct proportional for other mains voltages. The following conversion factors are meant for easy conversion: 100V = 2.3; 120V = 1.9; 240V = 0.96

- 1) P<sub>d</sub> = Power Dissipation
- 2) 1 BTU = 1055.06 J = 1055.06 Ws
- 3) Sine Signal Modulation (1 kHz)
- 4) Pink Noise according to EN60065 / 7. Edition
- 5) 10% Mains Over Voltage

## CONTRACTOR PRECISION SERIES

CPS2.9	U <sub>mains</sub> in V	I <sub>mains</sub> in A	P <sub>mains</sub> in W	P <sub>out</sub> in W	P <sub>d</sub> in W <sup>1</sup>	BTU/hr <sup>2</sup>
Idle	230	0.4	46	0	46	157
Max. Output Power @ 8 Ω <sup>3</sup>	230	9.4	1740	1100	640	2184
Max. Output Power @ 4 Ω <sup>3</sup>	230	15.3	2810	1800	1010	3446
1/3 Max. Output Power @ 4 Ω <sup>3</sup>	230	8.7	1450	600	850	2900
1/8 Max. Output Power @ 4 Ω <sup>3</sup>	230	3.6	560	225	335	1143
1/8 Max. Output Power @ 4 Ω <sup>4</sup>	230	3.6	540	225	315	1075
1/8 Max. Output Power @ 4 Ω <sup>4.5</sup>	253	4.1	690	275	415	1416
Normal Mode (-10 dB) @ 4 Ω <sup>3</sup>	230	3.2	460	160	300	1024
Rated Output Power (0 dB) @ 4 Ω <sup>3</sup>	230	14.4	2640	1600	1040	3549
Alert (Alarm) Mode (-3 dB) @ 4 Ω <sup>3</sup>	230	10.2	1770	800	970	3310
Max. Output Power @ 2 Ω <sup>3</sup>	230	21.6	4090	2800	1290	4402
1/8 Max. Output Power @ 2 Ω <sup>3</sup>	230	5.1	850	350	500	1706
1/8 Max. Output Power @ 2 Ω <sup>4</sup>	230	5.0	810	350	460	1570

CPS2.12	U <sub>mains</sub> in V	I <sub>mains</sub> in A	P <sub>mains</sub> in W	P <sub>out</sub> in W	P <sub>d</sub> in W <sup>1</sup>	BTU/hr <sup>2</sup>
Idle	230	0.5	57	0	57	194
Max. Output Power @ 8 Ω <sup>3</sup>	230	12.2	2100	1500	600	2047
Max. Output Power @ 4 Ω <sup>3</sup>	230	19.7	3620	2400	1220	4163
1/3 Max. Output Power @ 4 Ω <sup>3</sup>	230	11.2	1900	800	1100	3753
1/8 Max. Output Power @ 4 Ω <sup>3</sup>	230	4.7	720	300	420	1433
1/8 Max. Output Power @ 4 Ω <sup>4</sup>	230	4.7	705	300	405	1382
1/8 Max. Output Power @ 4 Ω <sup>4.5</sup>	253	5.3	880	375	505	1723
Normal Mode (-10 dB) @ 4 Ω <sup>3</sup>	230	4.1	625	220	405	1382
Rated Output Power (0 dB) @ 4 Ω <sup>3</sup>	230	18.9	3340	2200	1140	3890
Alert (Alarm) Mode (-3 dB) @ 4 Ω <sup>3</sup>	230	13.4	2330	1100	1230	4197
Max. Output Power @ 2 Ω <sup>3</sup>	230	27.5	5165	3600	1565	5340
1/8 Max. Output Power @ 2 Ω <sup>3</sup>	230	10.5	1810	450	1360	4640
1/8 Max. Output Power @ 2 Ω <sup>4</sup>	230	10.2	1730	450	1280	4368

Power consumption is direct proportional for other mains voltages. The following conversion factors are meant for easy conversion: 100V = 2.3; 120V = 1.9; 240V = 0.96

1) P<sub>d</sub> = Power Dissipation

2) 1 BTU = 1055.06 J = 1055.06 Ws

3) Sine Signal Modulation (1 kHz)

4) Pink Noise according to EN60065 / 7. Edition

5) 10% Mains Over Voltage

5.2 Block Diagram / Blockschaltbild

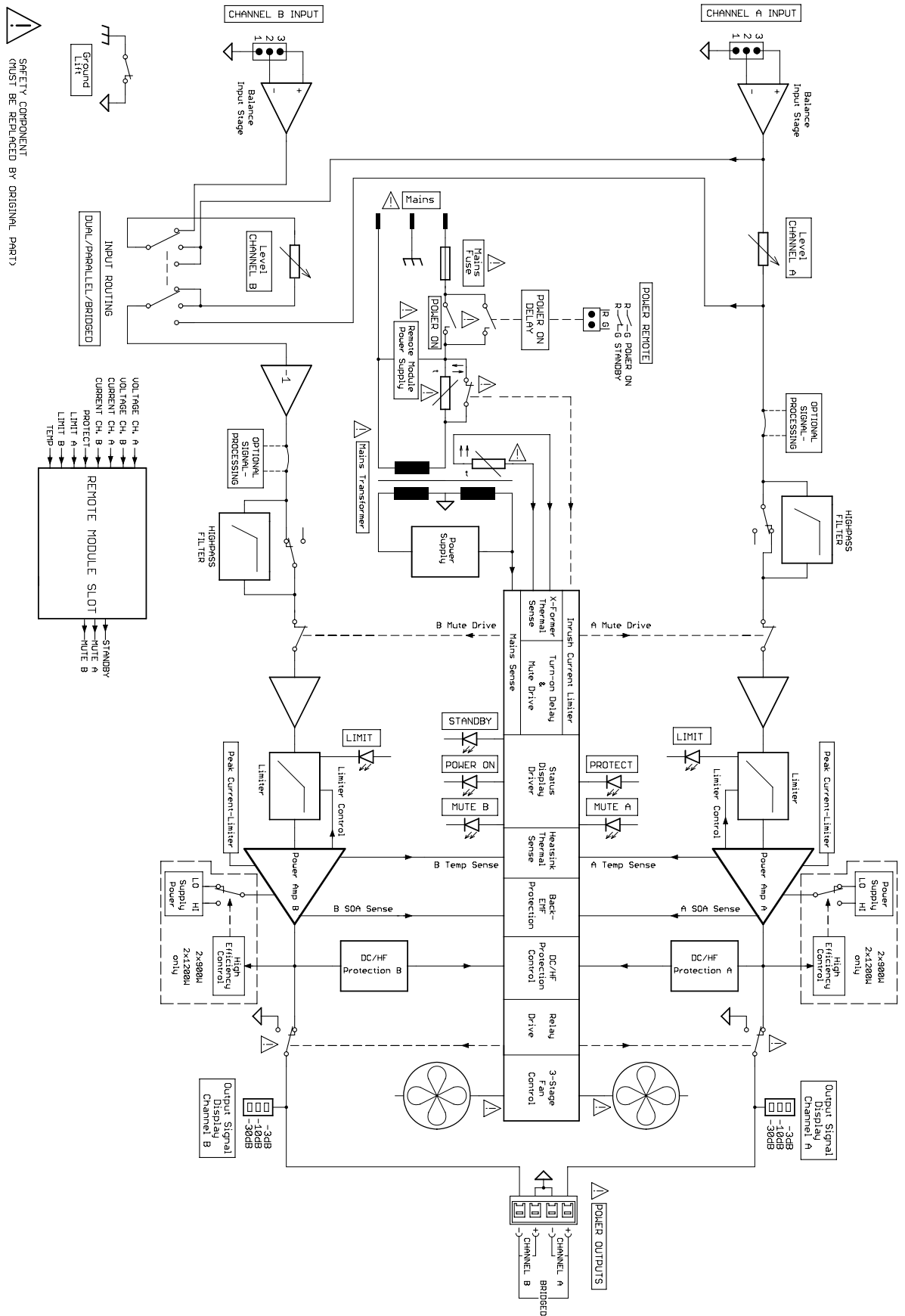

### 5.3 Dimensions / Abmessungen

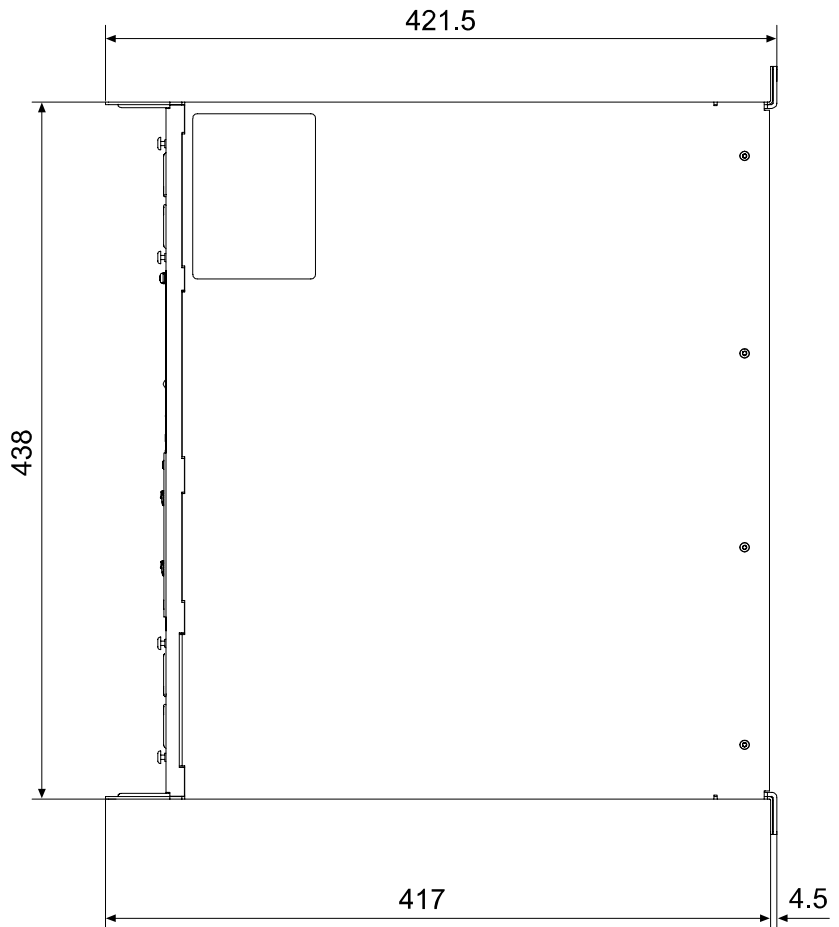
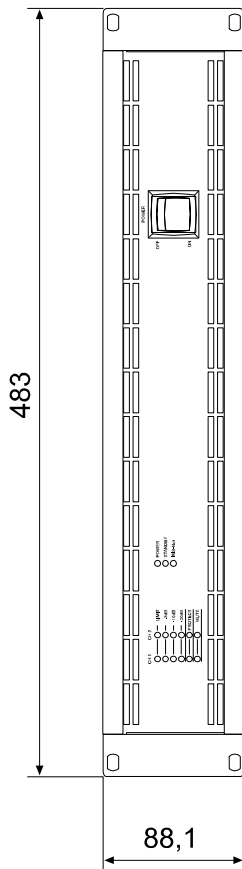
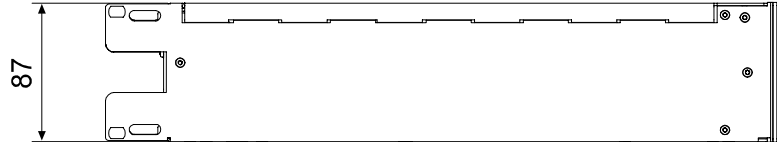
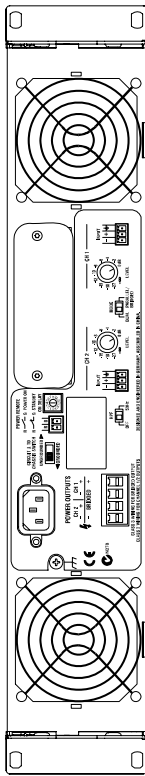



**AMERICAS**

Bosch Security Systems, Inc.  
12000 Portland Ave South  
Burnsville, MN 55337, USA  
USA-Phone: 1-800-392-3497  
Fax: 1-800-955-6831  
Canada-Phone: 1-866-505-5551  
Fax: 1-866-336-8467  
Latin America-Phone: 1-952-887-5532  
Fax: 1-952-736-4212

**EUROPE, AFRICA & MIDDLE-EAST**

Bosch Sicherheitssysteme GmbH  
Robert-Koch-Straße 100  
D-85521 Ottobrunn, Germany

*Contact & Visitor Address*  
EVI Audio GmbH  
Hirschberger Ring 45  
D-94315 Straubing, Germany  
Phone: +49 9421 706-0  
Fax: +49 9421 706-265

**ASIA & PACIFIC RIM**

Telex Pte. Ltd.  
3015A Ubi Road 1  
05-10 Kampong Ubi  
Industrial Estate  
Singapore 408705  
Phone: +65 6746-8760  
Fax: +65 6746-1206