

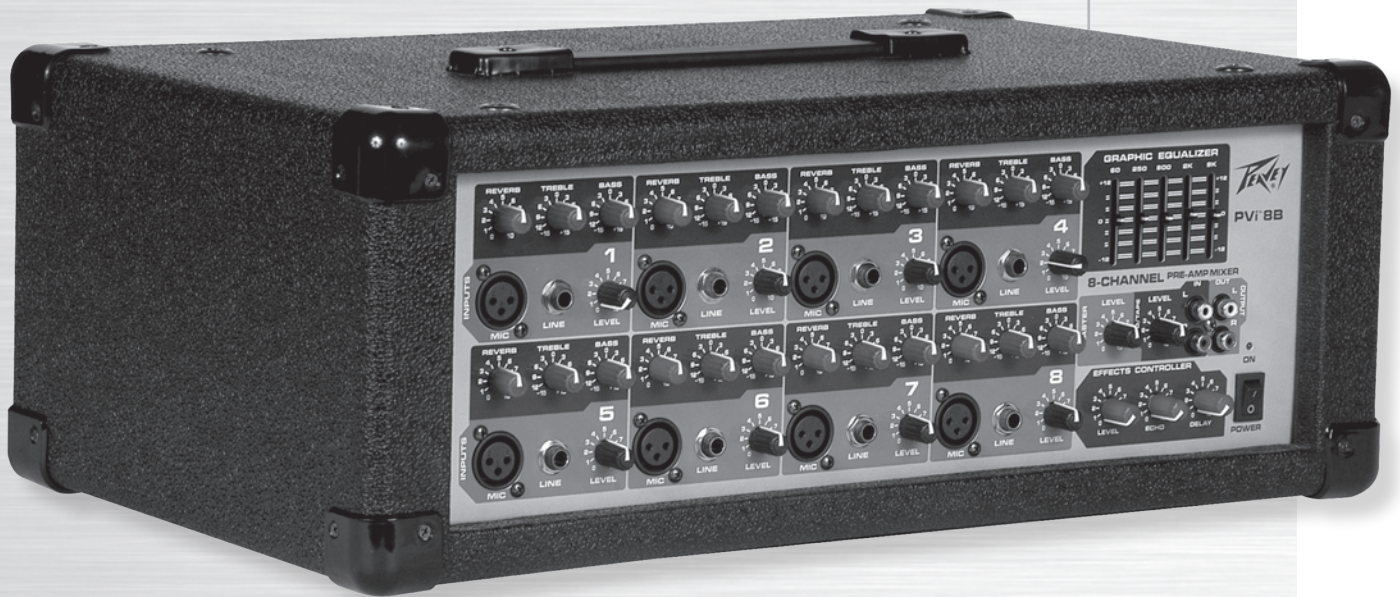

# PV™i 8B

## 150-WATT, 8-CHANNEL MIXER AMPLIFIER

### Operating Manual





Intended to alert the user to the presence of uninsulated “dangerous voltage” within the product’s enclosure that may be of sufficient magnitude to constitute a risk of electric shock to persons.



Intended to alert the user of the presence of important operating and maintenance (servicing) instructions in the literature accompanying the product.

**CAUTION:** Risk of electrical shock — DO NOT OPEN!

**CAUTION:** To reduce the risk of electric shock, do not remove cover. No user serviceable parts inside. Refer servicing to qualified service personnel.

**WARNING:** To prevent electrical shock or fire hazard, this apparatus should not be exposed to rain or moisture, and objects filled with liquids, such as vases, should not be placed on this apparatus. Before using this apparatus, read the operating guide for further warnings.



Este símbolo tiene el propósito, de alertar al usuario de la presencia de “(voltaje) peligroso” sin aislamiento dentro de la caja del producto y que puede tener una magnitud suficiente como para constituir riesgo de descarga eléctrica.



Este símbolo tiene el propósito de alertar al usuario de la presencia de instrucciones importantes sobre la operación y mantenimiento en la información que viene con el producto.

**PRECAUCION:** Riesgo de descarga eléctrica ¡NO ABRIR!

**PRECAUCION:** Para disminuir el riesgo de descarga eléctrica, no abra la cubierta. No hay piezas útiles dentro. Deje todo mantenimiento en manos del personal técnico cualificado.

**ADVERTENCIA:** Para prevenir choque eléctrico o riesgo de incendios, este aparato no se debe exponer a la lluvia o a la humedad. Los objetos llenos de líquidos, como los floreros, no se deben colocar encima de este aparato. Antes de usar este aparato, lea la guía de funcionamiento para otras advertencias.



Ce symbole est utilisé dans ce manuel pour indiquer à l'utilisateur la présence d'une tension dangereuse pouvant être d'amplitude suffisante pour constituer un risque de choc électrique.



Ce symbole est utilisé dans ce manuel pour indiquer à l'utilisateur qu'il ou qu'elle trouvera d'importantes instructions concernant l'utilisation et l'entretien de l'appareil dans le paragraphe signalé.

**ATTENTION:** Risques de choc électrique — NE PAS OUVRIR!

**ATTENTION:** Afin de réduire le risque de choc électrique, ne pas enlever le couvercle. Il ne se trouve à l'intérieur aucune pièce pouvant être réparée par l'utilisateur. Confiez l'entretien et la réparation de l'appareil à un réparateur Peavey agréé.

**AVIS:** Dans le but de réduire les risques d'incendie ou de décharge électrique, cet appareil ne doit pas être exposé à la pluie ou à l'humidité et aucun objet rempli de liquide, tel qu'un vase, ne doit être posé sur celui-ci. Avant d'utiliser de cet appareil, lisez attentivement le guide fonctionnant pour avertissements supplémentaires.



Dieses Symbol soll den Anwender vor unisolierten gefährlichen Spannungen innerhalb des Gehäuses warnen, die von Ausreichender Stärke sind, um einen elektrischen Schlag verursachen zu können.



Dieses Symbol soll den Benutzer auf wichtige Instruktionen in der Bedienungsanleitung aufmerksam machen, die Handhabung und Wartung des Produkts betreffen.

**VORSICHT:** Risiko — Elektrischer Schlag! Nicht öffnen!

**VORSICHT:** Um das Risiko eines elektrischen Schlages zu vermeiden, nicht die Abdeckung entfernen. Es befinden sich keine Teile darin, die vom Anwender repariert werden könnten. Reparaturen nur von qualifiziertem Fachpersonal durchführen lassen.

**WARNUNG:** Um elektrischen Schlag oder Brandgefahr zu verhindern, sollte dieser Apparat nicht Regen oder Feuchtigkeit ausgesetzt werden und Gegenstände mit Flüssigkeiten gefüllt, wie Vasen, nicht auf diesen Apparat gesetzt werden. Bevor dieser Apparat verwendet wird, lesen Sie bitte den Funktionsführer für weitere Warnungen.

## IMPORTANT SAFETY INSTRUCTIONS



**WARNING:** When using electrical products, basic cautions should always be followed, including the following:

1. Read these instructions.
2. Keep these instructions.
3. Heed all warnings.
4. Follow all instructions.
5. Do not use this apparatus near water.
6. Clean only with a dry cloth.
7. Do not block any of the ventilation openings. Install in accordance with manufacturer's instructions.
8. Do not install near any heat sources such as radiators, heat registers, stoves or other apparatus (including amplifiers) that produce heat.
9. Do not defeat the safety purpose of the polarized or grounding-type plug. A polarized plug has two blades with one wider than the other. A grounding type plug has two blades and a third grounding plug. The wide blade or third prong is provided for your safety. If the provided plug does not fit into your outlet, consult an electrician for replacement of the obsolete outlet.
10. Protect the power cord from being walked on or pinched, particularly at plugs, convenience receptacles, and the point they exit from the apparatus.
11. Only use attachments/accessories provided by the manufacturer.
12. Use only with a cart, stand, tripod, bracket, or table specified by the manufacturer, or sold with the apparatus. When a cart is used, use caution when moving the cart/apparatus combination to avoid injury from tip-over.
13. Unplug this apparatus during lightning storms or when unused for long periods of time.
14. Refer all servicing to qualified service personnel. Servicing is required when the apparatus has been damaged in any way, such as power-supply cord or plug is damaged, liquid has been spilled or objects have fallen into the apparatus, the apparatus has been exposed to rain or moisture, does not operate normally, or has been dropped.
15. Never break off the ground pin. Write for our free booklet "Shock Hazard and Grounding." Connect only to a power supply of the type marked on the unit adjacent to the power supply cord.
16. If this product is to be mounted in an equipment rack, rear support should be provided.
17. Note for UK only: If the colors of the wires in the mains lead of this unit do not correspond with the terminals in your plug, proceed as follows:
  - a) The wire that is colored green and yellow must be connected to the terminal that is marked by the letter E, the earth symbol, colored green or colored green and yellow.
  - b) The wire that is colored blue must be connected to the terminal that is marked with the letter N or the color black.
  - c) The wire that is colored brown must be connected to the terminal that is marked with the letter L or the color red.
18. This electrical apparatus should not be exposed to dripping or splashing and care should be taken not to place objects containing liquids, such as vases, upon the apparatus.
19. Exposure to extremely high noise levels may cause a permanent hearing loss. Individuals vary considerably in susceptibility to noise-induced hearing loss, but nearly everyone will lose some hearing if exposed to sufficiently intense noise for a sufficient time. The U.S. Government's Occupational Safety and Health Administration (OSHA) has specified the following permissible noise level exposures:

Duration Per Day In Hours	Sound Level dBA, Slow Response
8	90
6	92
4	95
3	97
2	100
1 1/2	102
1	105
1/2	110
1/4 or less	115

According to OSHA, any exposure in excess of the above permissible limits could result in some hearing loss. Ear plugs or protectors to the ear canals or over the ears must be worn when operating this amplification system in order to prevent a permanent hearing loss, if exposure is in excess of the limits as set forth above. To ensure against potentially dangerous exposure to high sound pressure levels, it is recommended that all persons exposed to equipment capable of producing high sound pressure levels such as this amplification system be protected by hearing protectors while this unit is in operation.

**SAVE THESE INSTRUCTIONS!**

# PV™i 8B

## 150-Watt, 8-Channel Mixer Amplifier

The PVi 8B powered mixer is easy to use and transport, and is designed with the latest Peavey technology. Constructed with a rugged metal structure, wood cabinet, vinyl surface and protective corners, the PVi 8B is the ideal powered mixer.

From packaging to quality control, we produce a product of maximum quality and efficiency with the same specifications you see on other, more expensive powered mixers.

Please read this guide carefully to ensure your personal safety as well as the safety of your equipment.

## Features

- ◆ 150 watts into 4-ohm (2 x 8 ohm) speakers
- ◆ Balanced microphone inputs
- ◆ Tape/CD inputs
- ◆ Reverb level control on each channel
- ◆ Line Out for connection to external amplifiers
- ◆ Return input for connection of external effects processors
- ◆ Record Out for taping
- ◆ RF interference protection on all inputs

## Front Panel

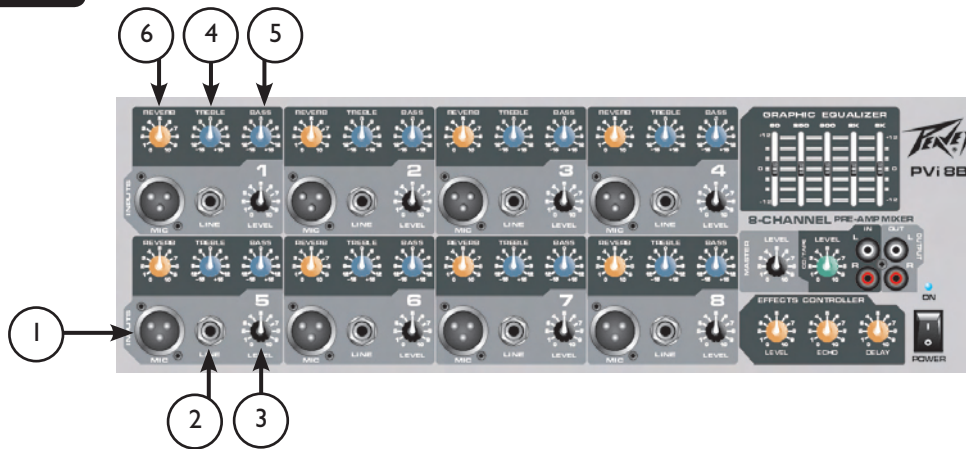

## Input Section

### (1) 3-PIN LOW-IMPEDANCE MICROPHONE INPUT

This input is for typical balanced, low-impedance microphones. It will automatically provide phantom power (15V) for condenser mics or active direct boxes. This has an input impedance of 1k ohms. The connector is wired as: Pin 1=shield; Pin 2=positive (hot); Pin 3=negative (cold).

### (2) 1/4" LINE/HIGH-IMPEDANCE INPUT

This input may be used as either a high-impedance microphone input or for line-level devices such as a cassette player, CD player, video projector or laptop. This will also allow connection from an electric guitar, bass or keyboard. It is a two-conductor input with an impedance of 10k ohms.

## Features

### (3) LEVEL CONTROL

The level control for each channel sends the signal to the master mix bus. Typical operation is between 4 and 8 (dependent upon the input devices) but should be lower than the master level. Please remember that this acts like a preamp, so if you are using a device that has a volume output control (i.e.: a tape or CD player) you will need to do some level matching by adjusting the level controls on each unit.

### (4) TREBLE TONE CONTROL

This is used to adjust the overall tone of the individual inputs. Since it is a cut or boost control (+/-15 dB), it will add or diminish presence frequencies in the sound beginning at 2 kHz.

### (5) BASS TONE CONTROL

This is used to adjust the overall tone of the individual inputs. Since it is a cut or boost control (+/-15 dB), it will add or diminish bass frequencies in the sound beginning at 300 Hz.

### (6) REVERB CONTROL

This is used as a send control to the effects bus. It controls the amount of reverberation added to the input signals.

## Front Panel

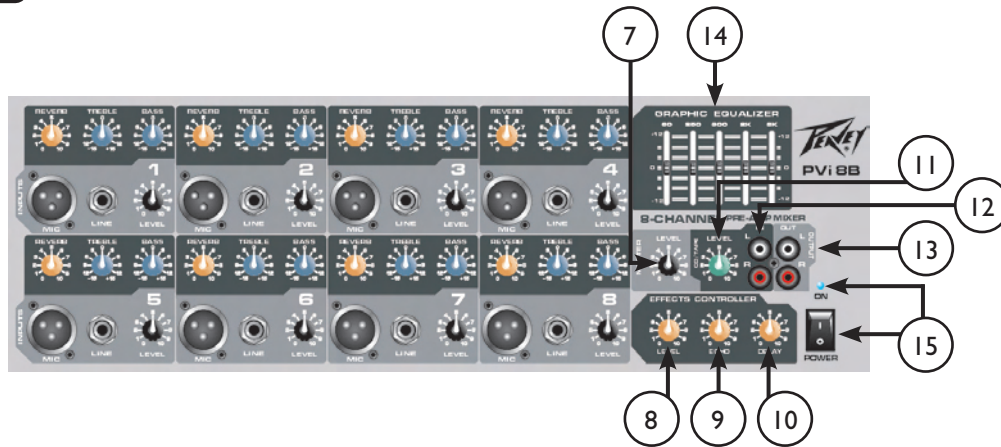

## Features

### (7) MASTER LEVEL

This controls the overall volume level of the entire amplifier. Typical operation is between 4 and 8.

### (8) EFFECTS VOLUME

This controls the level of the echo and delay that is added back to the master mix.

### (9) EFFECTS ECHO

This controls the character of the Reverb that is added back to the master mix. This is analogous with changing the rate at which the echo decays.

### (10) EFFECTS DELAY

This controls the delay of the Reverb that is added back to the master mix. Increase this control to simulate the effect of larger rooms.

### (11) TAPE/CD VOLUME

This controls the level of the playback inputs (RCA jacks).

### (12) TAPE IN (L/R)

These RCA jacks are for connecting a cassette deck, CD player or other line-level source.

### (13) TAPE OUT (L/R)

These RCA output jacks are primarily intended for connecting a tape deck, MP3 player, or other device for the purpose of recording from the mixer. Both channels are summed into mono for compatibility. The signals are taken pre-master section, meaning that they are without reverb or the master tone section, and do not include the Tape-In signal. If you wish to record with reverb and the Tape-In signals, use the 1/4" line output (2) with the proper cable.

### (14) MASTER EQ

These are used to adjust the overall EQ of the master mix. Since these cover five frequency bands (+/-15 dB), they will add or diminish the level of the sound at the indicated frequencies, spread across approximately one octave of frequency range. Most situations should require using no more than three controls simultaneously. Do not boost or cut all five at the same time. Excessive boosting will increase the probability of feedback.

### (15) POWER

This switches the unit on or off. When the unit is powered ON, the front-panel blue LED will illuminate.

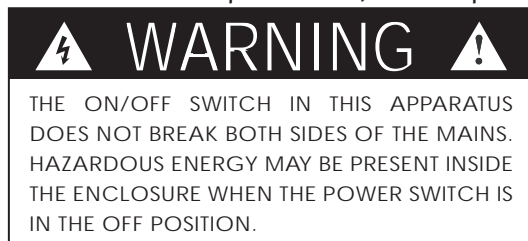

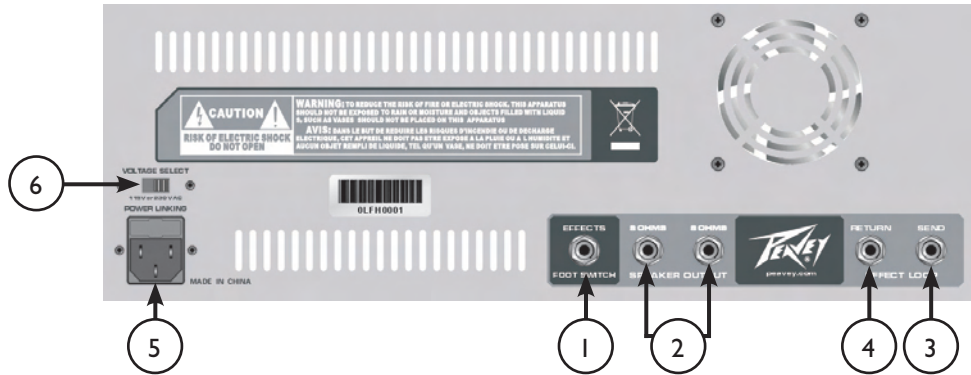

### (1) EFFECTS FOOTSWITCH

This switch provides for the connection of the optional remote footswitch. Footswitch is used to enable/disable reverb effects.

**CAUTION:** Connection of a voltage source into this jack will damage the mixer.

### (2) SPEAKER OUTPUTS

These are two-conductor 1/4" speaker outputs. Each one is rated at 8 ohms minimum impedance. Total minimum load for the amplifier is 4 ohms. You may connect either one 4-ohm, one 8-ohm or two 8-ohm speakers. Do not operate below rated minimum impedance. For maximum power transfer, be sure to use speaker cables and not instrument cables to connect to the speakers. We recommend the use of 18-gauge or larger speaker wire.

### (3) LINE SEND

This is a 1/4" two-conductor line output. It is intended to connect the mixer to the input of an external effects device or additional power amp, or to send a submix to a larger P.A. system. This line-level signal disconnects the main outputs.

### (4) LINE RETURN

This is a 1/4" two-conductor line input. It is intended primarily to connect the mixer to the output of an external effects device.

### (5) POWER LINKING CONNECTOR

This is a standard IEC cable connector for use with standard voltages from AC wall outlets. Its safety ground pin is connected to the chassis and should never be removed (or defeated in the line cord) for any reason. The IEC connector contains an internal fuse holder. The fuse rating is 5 amperes.

### (6) POWER SELECT SWITCH

This switch must be set properly for the local AC line voltage. Select between 115 (110-120 VAC) or 230 (220-240 VAC) using this switch.



# PV™i8B

## SPECIFICATIONS

**Output Power:**

150 watts / 4 ohms  
100 watts / 8 ohms

**Aux SEND Output:**

-10 dBv nominal, 1k ohms

**Tape REC Output:**

-10 dBv nominal, 1k ohms

**Input Impedance:**

Low-Z Mic: 1k ohms  
High-Z Line: 10k ohms  
Tape Input: 10k ohms

**Input Channel Equalization:**

Bass Control: 300 Hz  
Treble Control: 2000 Hz

**Master Graphic Equalization:**

60 Hz: +/- 15 dB  
250 Hz: +/- 15 dB  
800 Hz: +/- 15 dB  
2000 Hz: +/- 15 dB  
8000 Hz: +/- 15 dB

**Protection Circuit:**

Power on Mute delay time: 2 seconds

**Power Consumption:**

200 watts

**Dimensions (HxWxD):**

8" x 20 3/8" x 12 1/8"  
20.3 cm x 51.8 cm x 30.8 cm

**Weight:**

27.5 lbs. (12.5 kg)



Logo referenced in Directive 2002/96/EC Annex IV  
(OJ(L)37/38,13.02.03 and defined in EN 50419: 2005  
The bar is the symbol for marking of new waste and  
is applied only to equipment manufactured after  
13 August 2005





Features and specifications subject to change without notice.

Peavey Electronics Corporation • 5022 Hartley Peavey Drive • Meridian, MS • 39305

(601) 483-5365 • FAX (601) 486-1278 • [www.peavey.com](http://www.peavey.com)

EX 000042