

ALLEN & HEATH

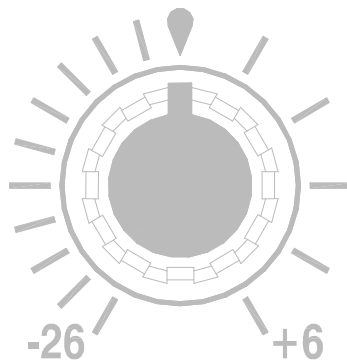

 **XONE:02**
P R O T U R N T A B L I S T D J M I X E R

USER GUIDE

Publication AP4500

Limited One Year Warranty

This product has been manufactured in the UK by ALLEN & HEATH and is warranted to be free from defects in materials or workmanship for period of one year from the date of purchase by the original owner.

To ensure a high level of performance and reliability for which this equipment has been designed and manufactured, read this User Guide before operating.

In the event of a failure, notify and return the defective unit to ALLEN & HEATH or its authorised agent as soon as possible for repair under warranty subject to the following conditions

Conditions Of Warranty

1. The equipment has been installed and operated in accordance with the instructions in this User Guide
2. The equipment has not been subject to misuse either intended or accidental, neglect, or alteration other than as described in the User Guide or Service Manual, or approved by ALLEN & HEATH.
3. Any necessary adjustment, alteration or repair has been carried out by ALLEN & HEATH or its authorised agent.
4. This warranty does not cover fader wear and tear.
5. The defective unit is to be returned carriage prepaid to ALLEN & HEATH or its authorised agent with proof of purchase.
6. Units returned should be packed to avoid transit damage.

In certain territories the terms may vary. Check with your ALLEN & HEATH agent for any additional warranty which may apply.



This product complies with the European Electromagnetic Compatibility directives 89/336/EEC & 92/31/EEC and the European Low Voltage Directives 73/23/EEC & 93/68/EEC.

This product has been tested to EN55103 Parts 1 & 2 1996 for use in Environments E1, E2, E3, and E4 to demonstrate compliance with the protection requirements in the European EMC directive 89/336/EEC. During some tests the specified performance figures of the product were affected. This is considered permissible and the product has been passed as acceptable for its intended use.

Allen & Heath has a strict policy of ensuring all products are tested to the latest safety and EMC standards. Customers requiring more information about EMC and safety issues can contact Allen & Heath.

NOTE: Any changes or modifications to the console not approved by Allen & Heath could void the compliance of the console and therefore the users authority to operate it.

XONE:02 User Guide AP4500 Issue 1

Copyright © 2001 Allen & Heath Limited. All rights reserved

Whilst we believe the information in this guide to be reliable we do not assume responsibility for inaccuracies. We also reserve the right to make changes in the interest of further product development.

Manufactured in the United Kingdom by

ALLEN&HEATH

Allen & Heath Limited
Kernick Industrial Estate, Penryn, Cornwall, TR10 9LU, UK

<http://www.allen-heath.com>



Important Safety Instructions – Read First

- Read instructions:** Retain these safety and operating instructions for future reference. Adhere to all warnings printed here and on the console. Follow the operating instructions printed in this User Guide.
- Do not open:** Operate the console with its front and crossfader panels correctly fitted. Disconnect mains power by unplugging the power cord if a panel needs to be removed for servicing. Refer this work to competent technical personnel only.
- Power sources:** Connect the console to a mains power only of the type described in this User Guide and marked on the rear panel. The power source must provide a good ground connection.
- Power cord:** Use the power cord with sealed mains plug appropriate for your local mains supply as provided with the console. If the provided plug does not fit into your outlet consult your service agent. Route the power cord so that it is not likely to be walked on, stretched or pinched by items placed upon or against it.
- Grounding:** Do not defeat the grounding and polarisation means of the power cord plug. Do not remove or tamper with the ground connection in the power cord.
- Ventilation:** Do not obstruct the ventilation slots or position the console where the air flow required for ventilation is impeded. If the console is to be operated in a rack unit or flightcase ensure that it is constructed to allow adequate ventilation.
- Moisture:** To reduce the risk of fire or electric shock do not expose the console to rain or moisture or use it in damp or wet conditions. Do not place containers of liquids on it which might spill into any openings.
- Heat:** Do not locate the console in a place subject to excessive heat or direct sunlight as this could be a fire hazard. Locate the console away from any equipment which produces heat such as power supplies, power amplifiers and heaters.
- Environment:** Protect from excessive dirt, dust, heat and vibration when operating and storing. Avoid tobacco ash, drinks spillage, and smoke, especially that associated with smoke machines.
- Handling:** To prevent damage to the controls and cosmetics avoid placing heavy objects on the control surface, scratching the surface with sharp objects, or rough handling and vibration. Protect the controls from damage during transit. Use adequate packing if you need to ship the unit.
- Servicing:** Switch off the equipment and unplug the power cord immediately if it is exposed to moisture, spilled liquid, objects fallen into the openings, the power cord or plug become damaged, during lightening storms, or if smoke, odour or noise is noticed. Refer servicing to qualified technical personnel only.
- Installation:** Install the console in accordance with the instructions printed in this User Guide. Do not connect the output of power amplifiers directly to the console. Use audio connectors and plugs only for their intended purpose.



Important Mains Plug Wiring Instructions

The console is supplied with a moulded mains plug fitted to the AC mains power lead. Follow the instructions below if the mains plug has to be replaced.

The wire which is coloured Green/Yellow or Green must be connected to the terminal in the plug which is marked with the letter E or with the Earth symbol.

This appliance must be earthed.

The wire which is coloured Blue or White must be connected to the terminal in the plug which is marked with the letter N.

The wire which is coloured Brown or Black must be connected to the terminal in the plug which is marked with the letter L.

Ensure that these colour codes are followed carefully in the event of the plug being changed.

Contents

Important Safety Instructions.....	3	Using Effects	16
Introduction and Quick Start.....	4	Linking Consoles.....	17
Connectors and Panel Controls	6	Recording.....	17
Installation and Cable Diagrams.....	10	Specification	18
Operating Instructions	12	Glossary	20
Replacing the Faders.....	15	Order Codes.....	22
Repositioning the Transform Switches.....	15	Tips and Troubleshooting	23

Introduction

Welcome to the **XONE:02** professional DJ mixer. This stylish and solidly built dual channel performance mixer presents a unique combination of creative tools for the professional turntablist or battle DJ. Above all, it features a sound quality second to none. **XONE:02** has been designed and constructed using the same rigorous standards we apply to our large format professional consoles used and respected by top engineers and performers throughout the world. We have had great fun designing this new range. We are sure you will get even more enjoyment using it.

We know you want to get started right away. For this reason we have kept this user guide concise and to the point. We recommend you read it through first. However, if even that is too much then at least read the QUICK START page before you plug up and go. This user guide refers to the **XONE:02**. For further information on the basic principles of audio system engineering and mixing technique please refer to one of the specialist publications available from bookshops and audio equipment dealers.

We are able to offer further product support through our world-wide network of approved dealers and service agents. You can also access our Web site on the Internet for information on our product range, assistance with your technical queries or simply to chat about matters audio. To help us provide the most efficient service please keep a record of your console serial number, and date and place of purchase to be quoted in any communication regarding this product.

Check out our home site www.allen-heath.com for information on the company and its pedigree, our full product range and our design philosophy. We also have a site dedicated to the exciting **XONE** console range www.xone.co.uk.

Key Features

- Dual stereo channels with mixable A and B inputs featuring independent level control and channel reverse
- A inputs switchable for line and RIAA phono sources
- 2 microphone inputs with vocal EQ, effect in/out and independent level control
- Balanced XLR main mix output with VCA master level control
- Booth output for local stereo monitoring
- EFFECT loop with silent FET switching to add external effects
- Link in and out connections for daisy chaining mixers, recording or booth output
- 3 Band +6/-26 asymmetric EQ with extended cut
- VCA PAN controls to adjust LR balance or for performance effect
- Ultra smooth gold contact dual rail conductive plastic VCA crossfader and channel faders
- All faders are VCA for noise free operation and have reverse and variable contour controls
- Rotatable TRANSFORM switches for stutter effects
- Removable face plate for fader servicing and user preferred transform switch positioning
- Advanced headphones cue system with cue/mix select, cue crossfader and large meters
- Sensible performance control layout makes it very easy to use
- Universal internal power supply for any worldwide mains voltage

- 1 Ensure your safety** First read and understand the Important Safety Instructions printed earlier. Make sure that all your equipment is set for your local mains supply voltage and correctly grounded to ensure your safety. Do not turn anything on until you have checked your wiring and control settings.
- 2 Set all controls to their starting position** Set channel FADERS, LEVELS, HEADPHONES, BOOTH and VCA MASTER controls minimum (anti-clockwise). Set PAN, EQ and CONTOUR controls centre. Set the CROSSFADER to CH1 and CUE fader to CH1. Set all switches up or out.
- 3 Plug in your sources and outputs** Plug in two music sources, one to CH1 the other to CH2 inputs A. Set the rear switches according to line or RIAA turntable source. Plug the LEFT and RIGHT OUT into the amplifiers feeding the main speakers, the LINK (BOOTH) OUT into the amps feeding the local DJ speakers, and plug in your stereo headphones. It is very important that the amplifier levels are turned right down at this stage.
- 4 Turn the system on** Switch on the mixer and music sources first. Check that the blue POWER indicator turns on. The meters may pulse as the power rails stabilise. This is quite normal. Finally switch on the amplifiers with their level controls turned down. The system should be quiet.
- 5 Adjust the level trims** Start the music playing and raise the INPUT A level control for each channel until its meter reads an average '0' with loud moments at '+5'. If the red 'PEAK' indicator flashes then back off the trim slightly. Slowly raise the headphones level control. You should hear the CH1 music signal. Slide the CUE fader across to CH2. You should now hear the CH2 music signal. If it sounds distorted, bassy or thin check that you have plugged it into the correct Line or Phono inputs.
- 6 Route the music to the main speakers** With music playing and crossfader set to CH1, raise the CH1 fader to its top '0' position. Next, raise the VCA MASTER control to maximum. Now slowly raise the amplifier level trim. You should start to hear the music through the main speakers. If you do not then check that the TRANSFORM switches are in their normal off position. Set the amplifiers for the loudest volume you want to allow in the room with console meters reading as described above. Now turn back the master for normal listening level. Move the CROSSFADER to the right and check the CH2 music signal. If you hear any hum or buzz check the system for bad wiring, ground loops or missing grounds, in particular those connecting to turntables.
- 7 Check the microphone** If you are using a microphone then plug it into MIC 1. We recommend you use a cardioid vocal dynamic type. Switch it on by pressing MIC ON and raise its LEVEL control until you hear it in the mix. Turn back the level if the mic starts to feed back.
- 8 Route the music to the booth monitor speakers** Now set the BOOTH level control to maximum and slowly turn up its amplifier level trim until the monitor is as loud as you need it to be relative to the main speakers. Setting the levels in this way prevents the DJ exceeding the allowed maximum by setting all controls to maximum. The meters provide an accurate display of the system capability.
- 9 Experiment with the channel faders and crossfader** With the two music sources playing you can experiment with these important performance controls. Adjust the fader CONTOUR control from a gentle fade to very steep cut to suit your mixing style. Press REVERSE to change the way the fader works. Try the PAN fader to move the sound between the left and right speakers. Also experiment with the small CUE fader which lets you preview your mix in the headphones first.
- 10 Experiment with the EQ** Now the creative fun bit. With one channel playing, listen to the effect of cutting or boosting the three EQ slider controls. Boost is restricted to +6dB to prevent system overload but you can cut up to a massive -26dB which almost completely sucks out or 'kills' the selected frequency band. Watch the meters and pull back the input level if it peaks. Experiment with the mic EQ which is optimised for vocal adjustment. Some LO cut helps reduce the annoying popping noise when you talk close to the mic. A little mid boost may help warm up a dull sounding mic, some HI boost can help cut through the mix, or use cut if you are plagued by feedback.
- 11 Experiment with the TRANSFORM switches** The transform switch simply turns the channel on or off. Use this for 'stutter' effects popular with performance DJs.
- 12 Now that you have started...** Experiment further with all the controls, keeping the volume at a low level until you are sure what each does. Refer to the section on using the EFFECTS LOOP later in this guide for details on how to add external effects such as delay and reverb. To find out more about each control continue to read through this guide. **HAPPY MIXING !**



Important Note about Hearing : To avoid damage to your hearing do not operate any sound system at excessively high volume. This also applies to any close-to-ear monitoring such as headphones. Continued exposure to high volume sound can cause frequency selective or wide range hearing loss. Make sure that your system complies with any venue sound level and noise regulations which may apply.

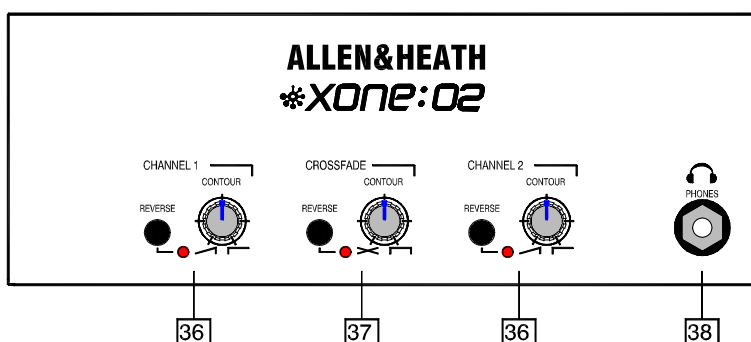
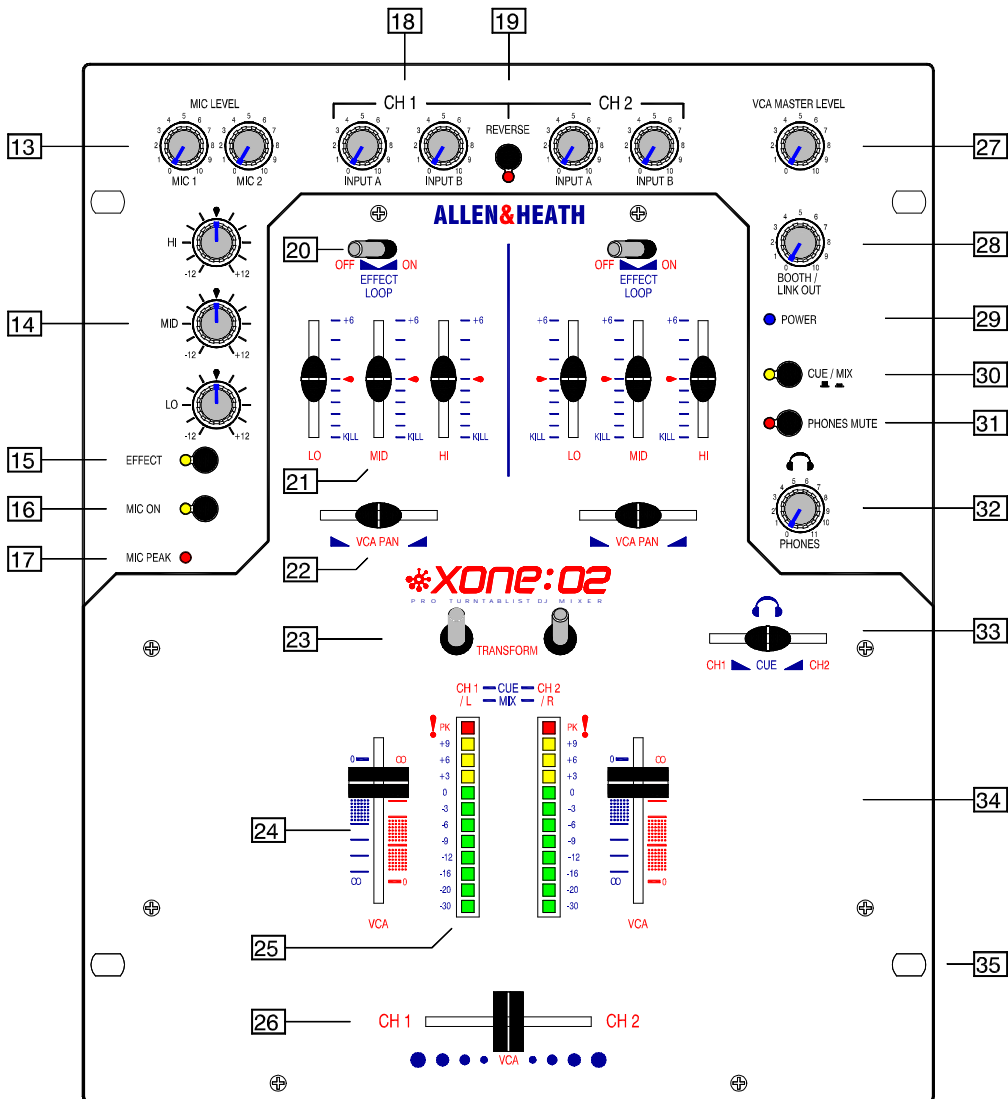
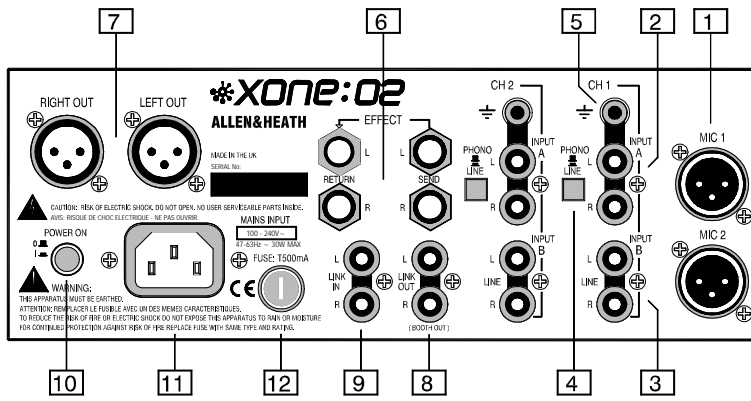

Connectors and Panel Controls

1 **MIC input** 2x XLR. Plug in one or two microphones for the DJ and/or MC. Use a rugged cardioid dynamic type intended for vocals. Do not use phantom powered microphones. Make sure you connect using good quality balanced microphone cables.

2 **INPUT A** Dual RCA phono. Plug in your stereo music sources. This input can be switched for RIAA equalised turntable or non-equalised sources such as CD.

3 **INPUT B** Dual RCA phono. Plug in additional line level stereo sources such as CD, MD, DAT, drum machines, keyboards or other instruments. Do not connect turntables which require RIAA equalisation.

4 **INPUT SELECT switch** Selects either PHONO or LINE input source. Press for LINE, release for PHONO. For turntables with magnetic cartridges requiring RIAA equalisation select PHONO. For non-RIAA turntables select LINE instead. For other non-RIAA sources such as CD select LINE. These switches are positioned on the rear panel to prevent accidental operation during performance.



Do not plug in line level sources with PHONO selected as these will overload the preamp and cause severe high level distortion.

5 **CHASSIS earth** A screw terminal is provided for connecting the earth straps from turntables. This connection earths (grounds) the metal parts of the turntable to reduce hum, buzz or similar audible noise getting into the system. Make sure the terminal is fully tightened once the strap is in place.

6 **EFFECT send and return** 2x dual TRS jack. Selecting a channel EFFECT LOOP ON switch routes its signal out of the EFFECT SEND sockets to an external effects processor such as delay or sampler unit instead of direct to the mix. The processed signal is returned to the mix through the EFFECT RETURN sockets. Plug in your favourite line level effects processor. With nothing plugged in the channel send is automatically routed through switching contacts in the return sockets back to the mix.

7 **LEFT and RIGHT MIX output** 2x XLR. This is the main stereo output that feeds the house PA. The output is electronically balanced so it can drive long cable runs to balanced equipment without interference pickup. It can also be wired to connect to unbalanced equipment.

8 **LINK (BOOTH) output** Dual RCA phono. This additional stereo output is derived from the main mix and can be used in several different ways. You can link consoles together, for example when battle mixing by connecting it to the LINK input on the next **XONE:02**. You can record your performance by connecting to a 2-track recorder such as MD or DAT. You can feed an independent DJ's local monitor by connecting it to a booth amplifier input. You can provide a separately controlled zone output.

9 **LINK input** Dual RCA phono. Stereo line input that connects directly to the main mix. It is not affected by the VCA MASTER LEVEL or any other control. Use this input when linking another console to the **XONE:02**.

10 **POWER ON switch** This rear panel push switch turns the console on or off.



To avoid loud thumps or damage to your speakers always turn amplifiers off before turning the console or other equipment in the signal chain on or off. Turn amplifiers on last and off first.

11 **MAINS input** IEC socket. Plug the AC mains supply in here. A country dependent mains lead with moulded plug is provided with the console.



Ensure the local mains voltage is within the range specified on the panel and that the connection is correctly grounded.

12 **FUSE** This is the mains input protection fuse for the internal power supply. In the unlikely event of it failing make sure you replace it with the same type and rating. If the replacement fails get the console checked by your service agent.

13 **MIC level controls** Trims the gain of each input preamp to match the connected microphone to the operating level of the console. Turn back the level control if the PEAK indicator flashes. The two mic inputs have independent level control and sum together into the equaliser.

14 **MIC EQ** The equaliser provides three controls to let the DJ adjust the tone of the microphone either to enhance the sound or to deal with problems such as acoustic feedback. **HI** and **LO** have a shelving response that boosts or cuts the high (treble) or low (bass) frequencies. Use **HI** boost to add vocal 'bite' around 6.5kHz, cut to reduce harshness or high frequency feedback. It is best to use the 120Hz **LO** cut to reduce the popping effect when speaking close to a dynamic mic. **MID** has a bell shaped response that boosts and cuts frequencies around 2.5kHz which helps to enhance vocal intelligibility or control feedback.

15 **EFFECT switch** Press this switch to route the mic signal through the effects loop instead of direct to the mix. This lets you send the signal to an external processing device such as a sampler or echo unit before returning it to the mix.

16 **MIC ON switch** Use this to turn the mic signal on or off. The green indicator lights when the mic is on.

17 **MIC PEAK indicator** Lights to warn you when the mic signal is within 6dB of clipping. Turn back the MIC LEVEL control if it lights.

18 **CHANNEL INPUT level controls** Independently adjusts the level of the INPUT A and INPUT B signals for each stereo channel. Adjust these so that the CUE meters read around '0' with loudest moments around '+6'. If the red 'PEAK' indicators light then turn back the level control.

19 **REVERSE switch** Reverse the CH1 and CH2 inputs to move the signal to the opposite channel controls. This effectively puts the crossfader into hamster mode and gives the DJ even greater performance flexibility.

20 **EFFECT LOOP switch** Use this during performance to toggle the effect in or out for the channel. This routes the music signal to an external signal processor to add effects such as sampler or echo before returning it to the mix.

21 **Channel EQ** The equaliser has three controls to let the DJ creatively alter and shape the sound during live performance. The music frequency spectrum is divided into 3 bands. **HI** (10kHz) has a shelving response and affects the high frequency (treble) sounds, **MID** (1kHz) has a peak/dip bell shaped response and affects mid range (presence) sounds, and **LO** (100Hz) has a peak/dip bell shaped response and affects low (bass) sounds. The HI and LO bands feature sharp 12dB/octave response which enhances their effect on the music. This type of equaliser is known as 'asymmetric' because the amount of boost and cut is not the same. Boost is restricted to a safe +6dB to highlight selected sounds while preventing system overload through heavy use. Cut on the other hand, is increased to a huge -26dB to completely suck out affected frequencies dramatically changing the effect. Use cut rather than boost to create your dramatic performance effects.

22 **VCA PAN slider** Adjusts the balance between the channel left and right stereo signals. Each side ranges from fully off to fully on. The control has unity gain in the centre equal and extreme full on positions. At the extreme ends the opposite signal is fully off. This slider can be used to create dramatic panning effects during performance.

23 **TRANSFORM switch** This hard wearing control lets you create cut effects by instantly muting the music signal. Flick the switch lightly with the fingers in time to the beat to create the popular 'transform' or 'stutter' effects. The switches can be repositioned upside down or sideways to suit the preference of the DJ.

24 **Channel FADER** Also known as the 'up fader' this controls the music level from fully off to on. It is used by the DJ to select the channel to the crossfader and as a performance control to create exciting finger operated effects. Long life is assured as the **XONE:02** uses high quality dual rail gold contact faders together with VCA circuitry which means that no audio is passed through the fader itself. Its response can be finely tuned to the mixing style of the DJ using the CONTOUR and REVERSE functions [\[36\]](#). It can be easily replaced if it becomes damaged or worn through exceptional mechanical operation.

25 **Channel METER** When the **CUE** switch [\[30\]](#) is in its up position these meters display the CH1 and CH2 signal levels. The left and right signals are summed to display the channels in mono. When pressed the meters display the left and right main mix outputs instead. Each meter has 12 LEDs to indicate signal levels from a low -30dB. Green and yellow LEDs indicate normal operating levels. The top red PEAK led lights at +15dB giving you plenty of warning that you are within 7dB of clipping. Meter '0' represents +4dBu at the XLR outputs. The meters are peak responding with a fast attack and are therefore able to display fast transients accurately. This makes it easier to keep track of the highest levels and transient peaks.



Do not operate the console with these meters lighting red more than the occasional flash. Failure to observe this can result in severe signal distortion which may damage equipment.

26 **CROSSFADER** The crossfader lets you smoothly fade from one track into another using a single fader. It is also used as a creative performance tool to layer or interact between two sounds when cut or scratch mixing. It can be easily replaced if it becomes damaged or worn through exceptional mechanical operation. Long life is assured as the **XONE:02** uses a high quality dual rail gold contact crossfade type together with VCA circuitry which means that no audio is passed through the fader itself. The response of the crossfader can be adjusted to match your mixing style using the CONTOUR and REVERSE controls [\[37\]](#).

27 VCA MASTER level A rotary master control adjusts the output level feeding the house PA. This is a stereo control which adjusts the left and right signals at the same time. It affects the stereo MIX and booth / link outputs. Note that it does not affect the cue signal feeding the headphones. The maximum position represents unity (0dB) gain. If you find yourself normally setting the control in the lower part of its travel then the connected equipment may be too sensitive for the operating level of the console. With the control set to its maximum position adjust the input level trim of connected equipment for the loudest level allowed.



In a club or similar installation strict sound level and noise regulations may apply. Check that your system levels are set up to comply.

28 BOOTH / LINK OUT level Adjusts the level of the signal to the stereo booth monitor or level feeding another console when linking. It is affected by the VCA MASTER level control. It does not affect the level in the headphones.

29 Power indicator The cool blue LED lights when the console is powered.

30 CUE / MIX switch In its normal up position the output of the CUE fader is sent to the stereo headphones. The meters display the CH1 and CH2 signals summed in mono. When pressed the MIX output signal is sent to the headphones and the stereo signal displayed on the meters. Use the CUE/MIX switch and CUE fader to check and preview your mix before going live.

31 PHONES MUTE switch Turns off the signal to the headphones. Use this when you want to check the sound of the house or booth system without distraction from the headphones. The red LED lights when the signal is muted.

32 PHONES LEVEL control Adjusts the level of the signal in the stereo headphones. This does not affect the level of the booth monitor.



WARNING: Some headphones are more sensitive than others and can produce higher output levels. To avoid damage to your hearing start with the level control at minimum and turn up only as much as is needed to maintain comfortable listening level. Do not drive headphones at high listening levels for long periods of time.

33 CUE slider This affects what you hear in the headphones when the CUE/MIX switch is in its up position. When fully left only the CH1 signal is routed. When fully right only the CH2 signal is routed. Move the slider to hear the effect of mixing or cross fading the signals. This lets you preview the mix in your headphones before going live. It does not affect the booth or house mix.

34 Top panel The top panel can be removed to allow fader access and repositioning of the TRANSFORM switches. This is done by removing fader knobs and the 8 fixing screws.

35 Mounting holes Use these to fix the **XONE:02** into a plinth, rack or other equipment furniture. Note the dimensions in the specification section later in this user guide. M6 pan head screws with protective plastic cups are recommended.

36 CROSSFADE REVERSE and CONTOUR controls The REVERSE switch swaps the X and Y sides of the crossfader so that CH1 feeds the right side and CH2 feeds the left side. It is also known as the 'hamster' effect. The CONTOUR control varies the law of the crossfader from a gentle fade with 6dB dip at centre position to a very sharp fade where full level is achieved just a few millimetres from the end stop. These controls can be adjusted to suit the DJ's preference or mixing style and further enhance the creative performance flexibility of the **XONE:02**.

37 CHANNEL FADER REVERSE and CONTOUR controls These provide the same function as the crossfade controls described above. The advanced VCA circuitry enables long life reliability and the ability to fine tune the response of the performance controls to your exact needs.

38 PHONES socket This output is positioned on the front panel so that the DJ can plug favourite headphones in without needing access to the rear. Headphones are available in many different styles, impedances and volume ratings. To get the best from your system we recommend that you use high quality closed-ear headphones around 70 ohms impedance, although 30 to 600 ohms will work. 8 Ohm headphones are not recommended. Avoid using mini-jack to ¼" jack adapters as these may quickly prove unreliable.

Installation

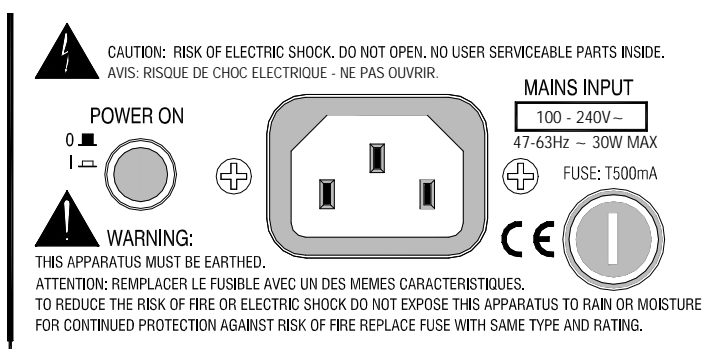

Connecting Mains Power Read the SAFETY INSTRUCTIONS printed at the front of this User Guide and on the rear panel. Check that the correct mains lead with moulded plug has been supplied with your console. The power supply accepts 50/60Hz AC mains voltages within the range 100-240V without changing any fuses or settings.

It is standard practice to turn connected power amplifiers down or off before switching the console on or off. This prevents any audible switch-on thumps. Ensure that the IEC mains plug is pressed fully into the rear panel socket before switching on.

Earthing

The connection to earth (ground) in an audio system is important for two reasons:

1. **SAFETY** - To protect the operator from high voltage electric shock, and
2. **AUDIO PERFORMANCE** - To minimise the effect of earth (ground) loops which result in audible hum and buzz, and to shield the audio signals from interference.

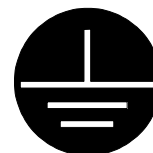

For safety it is important that all equipment earths are connected to mains earth so that exposed metal parts are prevented from carrying high voltage which can injure or even kill the operator. It is recommended that the system engineer check the continuity of the safety earth from all points in the system including microphone bodies, turntable chassis, equipment cases, and so on.

The same earth is also used to shield audio cables from external interference such as the hum fields associated with power transformers, lighting dimmer buzz, and computer radiation. Problems arise when the signal sees more than one path to mains earth. An 'earth loop' (ground loop) results causing current to flow between the different earth paths. This condition is usually detected as a mains frequency audible hum or buzz.

To ensure safe and trouble-free operation we recommend the following:

- **Have your mains system checked by a qualified electrician** If the supply earthing is solid to start with you are less likely to experience problems.
- **Do not remove the earth connection from the console mains plug** The console chassis is connected to mains earth through the power cable to ensure your safety. Audio 0V is connected to the console chassis internally. If problems are encountered with earth loops operate the audio 'ground lift' switches on connected equipment accordingly, or disconnect the cable screens at one end, usually at the destination.
- **Make sure that turntables are correctly earthed** A chassis earth terminal is provided on the console rear panel to connect to turntable earth straps.
- **Deal with ground loops** Should you experience hum or buzz caused by ground loops, check first that each piece of equipment has its own separate path to ground. If so, operate ground lift switches on connected equipment in accordance with the instruction manuals. Alternatively disconnect the cable screen at the destination end only. This breaks the offending loop while still maintaining the signal shielding down the length of the cable.
- **Use low impedance sources** such as microphones and line level equipment rated at 200 ohms or less to reduce susceptibility to interference. The console outputs are designed to operate at very low impedance to minimise interference problems.
- **Use balanced connections for the microphone and main outputs** as these provide further immunity by cancelling out interference that may be picked up on long cable runs. Refer to the cable drawing for information on how to connect balanced and unbalanced equipment.
- **Route cables to avoid interference** To avoid interference pickup keep audio cables away from mains power units and cables, thyristor dimmer units or computer equipment. Where this cannot be avoided, cross the cables at right angles to minimise interference.
- **Use good quality cables and connectors** and check for correct wiring and reliable solder joints. Allow sufficient cable loop to prevent damage through stretching.
- **If you are not sure ...** Contact your service agent or local Allen & Heath dealer for advice.

Cables and Connections

The **XONE:02** uses professional grade 3 pin XLR, 1/4" TRS jack and RCA PHONO sockets. The following mating plugs may be used:

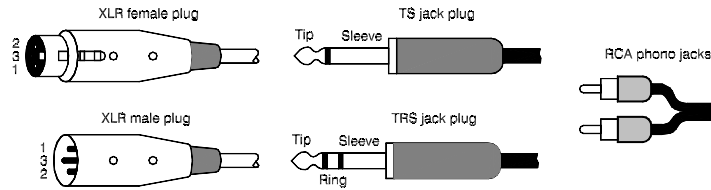

The **XLR** connector is 3 wire balanced. This has 3 connector pins: Pin 1 = ground (screen), Pin 2 = signal hot (+), Pin 3 = signal cold (-). The jack sockets are the 3 pole **TRS** type. These are wired to work with either the balanced TRS or the unbalanced 2 pole TS type plugs without cable modification. The sockets have 3 connector pins: Inputs and outputs are Tip = signal hot (+), Ring = signal cold (-), Sleeve = ground (screen). Headphones are Tip = left, Ring = right, Sleeve = ground. The **RCA** phono connectors are 2 wire unbalanced to connect to equipment such as CD players, turntables and domestic amplifiers.

To ensure best performance, we recommend that you use high quality audio cables and connectors, and take time to check for reliable and accurate cable assembly. It is well known that many audio system failures are due to faulty interconnecting leads. Avoid reversing + and - on balanced connections as this will result in reverse polarity connections which may cause signal cancellation effects. Refer to the cable diagram for how to wire unbalanced to balanced connections. **It is fine to use a Y-adapter to feed one output to several inputs, but never use a Y-adapter to sum two outputs into one input.**

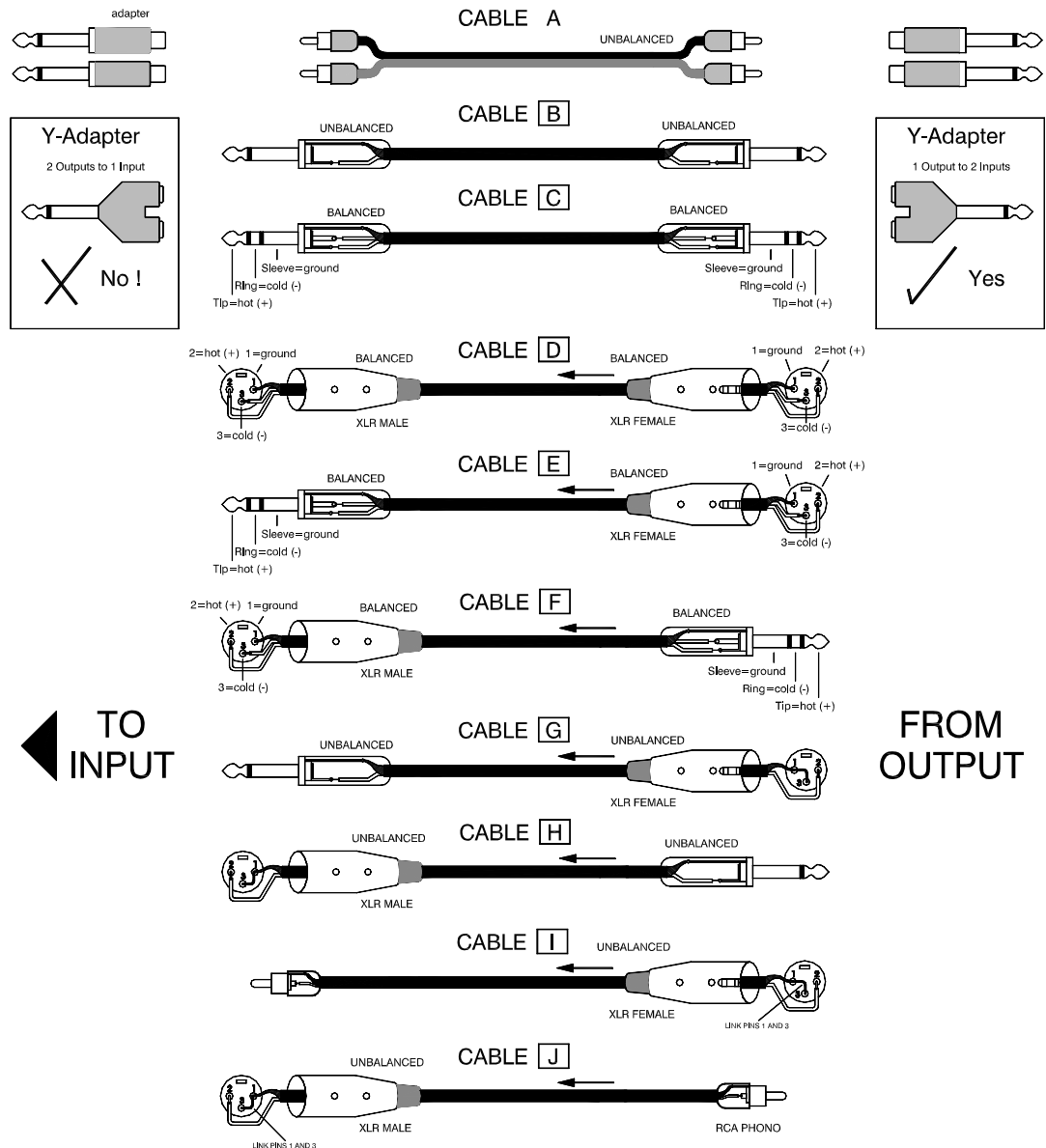

Operating Instructions

The QUICK START page near the beginning of this user guide gives you a quick introduction to using the **XONE:02** if you want to get going right away. You can achieve much simply by experimenting and trying out different combinations of settings. The notes here provide further information to get the most out of your console. It is not intended as a guide to how to mix or structure your performance. That is your art...

Overview of the Application

This diagram shows an example hook-up to demonstrate how the **XONE:02** can be connected in a typical DJ application. Note that the connector types on the equipment you connect to may be different to that shown. Use cables appropriate to your application. Please read the INSTALLATION section before connecting to your equipment. The following describes this example application:

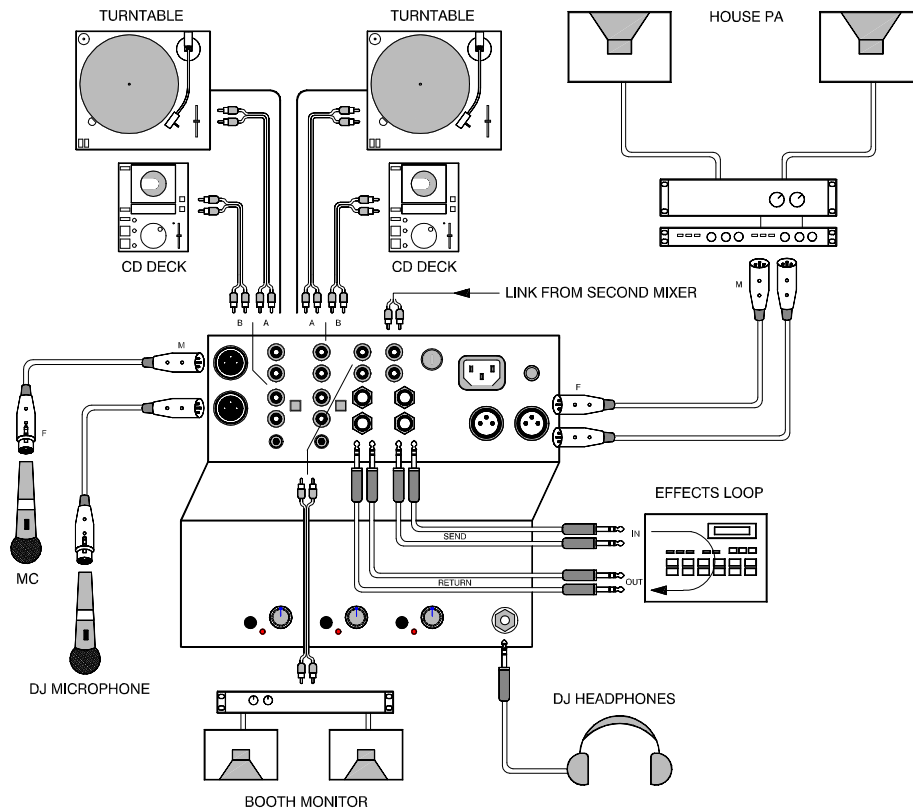

DJ Microphone and Headphones: The DJ plugs in the preferred headphones and microphone. A second mic for the MC may also be required. The console cue system works with the headphones to let the DJ cue tracks and preview the mix before going live.

Mix music sources: Two dual input channels are used for the mix music sources. Here, both a turntable and a CD deck are plugged into each, one for each side of the crossfader. The turntable magnetic cartridges plug into the RIAA equipped phono inputs, the CD into the line inputs. This gives the DJ the choice of vinyl or CD mixing. Alternatively, the DJ could plug other sources such as a drum machine into the line input.

Adding effects: The stereo effects send is used to route the channel to an external effects unit such as a sampler or echo device. Its output is returned to the mix through the Effects return. This is known as an 'effects loop'. The effects unit can be switched in or out of each music channel and the mix channel independently. Adding effects in this way greatly enhances the performance of the DJ helping create a unique interpretation of the music.

Mix output: This stereo output feeds the house PA system to provide quality sound to the dance floor. The connections are balanced to feed long cable runs to the amplifier system. They may plug into system processors such as protection limiters, EQ and crossovers which connect to the amplifiers.

Booth monitor: A stereo speaker system provides the DJ with a local monitor. This has its own level control so it can be adjusted to suit without affecting the house sound.

Recording the mix: Alternatively, the booth feed could be connected to a recorder such as the MiniDisc shown to record the DJ's set, or to both using a Y-adapter.

Linking consoles: The output of one **XONE:02** can be linked into the input of another. This is convenient for battle mixing where several DJs may be mixing together into the same system, each with their own console.

Gain and Operating Levels

It is most important that the system gain and level settings are correctly set. It is well known that many DJs push the gain to maximum with meters peaking hard in the belief that they are getting the best from the system. **THIS IS NOT THE CASE !** The best can only be achieved if the system levels are set within the normal operating range and not allowed to peak. Peaking simply results in signal distortion, not more volume. It is the specification of the amplifier / speaker system that sets the maximum volume that can be achieved, not the console. The human ear too can fool the operator into believing that more volume is needed. Be careful as this is in fact a warning that hearing damage will result if high listening levels are maintained. Remember that it is the **QUALITY** of the sound that pleases the ear, not the **VOLUME**.

Use the **LEVEL** control to match the input source to the normal operating level of the console. Adjust this so that the **CUE METER** averages 0dB with loudest moments reading +6. Listen to the signal on headphones. Adjust the **VCA MASTER LEVEL** so that it normally operates near the top of its travel. Make sure the amplifier/speaker system has been correctly calibrated for the loudest volume required at the channel fader top position. Boosting the EQ also adds gain to the system. Reduce by turning back the **LEVEL** control if the meter red peak LEDs flash. Adjust the **HEADPHONES** and **BOOTH** monitor controls for safe listening levels.

The diagram illustrates the operating range of the audio signal.

NORMAL OPERATING RANGE. For normal music the signal should range between -6 and +6 on the meters with average around 0dB. This allows enough **HEADROOM** for unexpected peaks before the signal hits its maximum **CLIPPING** voltage and distorts. It also achieves the best **SIGNAL-TO-NOISE-RATIO** by keeping the signal well above the residual **NOISE FLOOR** (system hiss). The **DYNAMIC RANGE** is the maximum signal swing available between the residual noise floor and clipping. The **XONE:02** provides a massive 108dB dynamic range.

A final note ... The human ear is a remarkable organ with the ability to compress or 'shut down' when sound levels become too high. Do not interpret this natural response as a reason to turn the system volume up further ! As the session wears on ear fatigue may set in, and the speaker cones may become hot so reducing the effectiveness of the system and listeners to gain any benefit from increased volume.

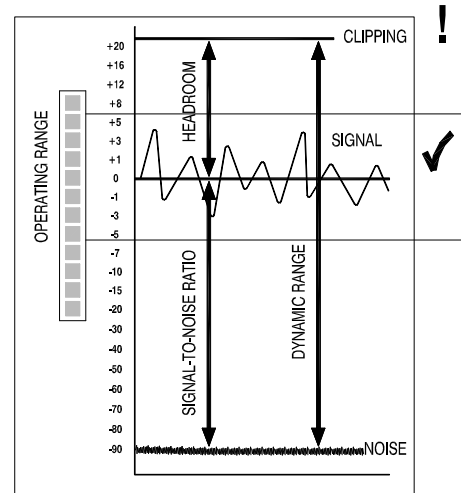

BE SENSIBLE, BE SAFE WITH SOUND LEVELS



Using the Channel EQ

With the 3 EQ controls set to their centre detented position the EQ has no effect on the sound. The asymmetric EQ design provides a huge amount of cut to suck out selected frequencies for dramatic effect, and a restricted amount of boost to enhance frequencies without overloading the system. Move the sliders up to boost the selected band of frequencies by up to 6dB. Pull them back to cut the frequencies by up to 26dB.

Cutting low, mid or high frequency bands can be very effective when layering one track on another. This lets you enhance the sounds you want while cutting those you don't want. For example, you could fade in the high frequency cymbal line of the CH2 track on top of the currently playing CH1 track by cutting the MID and LO EQ on CH2. Learn what the EQ can do by playing a selection of tracks and experimenting with the controls.

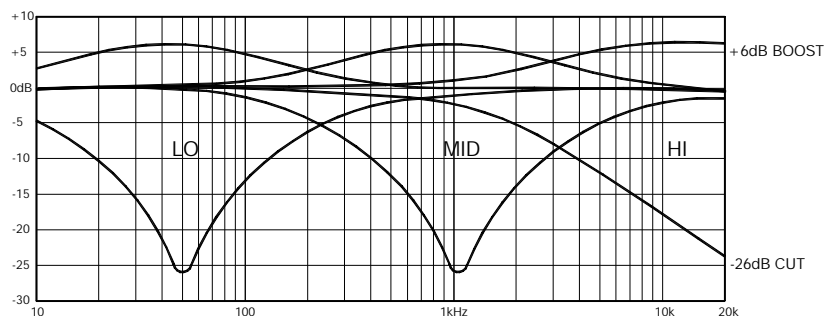

Using the Crossfader

The crossfader is the one feature that instantly sets the DJ mixer apart from a conventional mixer. It lets you smoothly fade from one track into another using a single fader. It is also used as a creative performance tool to layer or interact between two sounds when cut or scratch mixing. A high grade dual rail fader with long lasting gold contacts is used. The ultra high quality Penny & Giles type can be fitted as an option if preferred.

The **XONE:02** uses four high performance voltage controlled amplifiers (VCAs), a pair for each side of the stereo crossfader. The robust 45mm fader produces a DC control voltage which determines the signal level of the VCAs. The voltage is filtered to prevent any audible noise, clicks or scratchiness resulting should the fader track become worn. This benefit would not be possible if the signal were routed through a conventional audio fader. Using the fader as a controller also means that its response can be easily tailored to suit the mixing style.

CH1 feeds the left side of the crossfader so that all the signal is routed when the fader is at its fully left position. CH2 feeds the right side of the crossfader.

Use the **CONTOUR** control to adjust the way the fader responds as you move it. You can adjust from a very gentle fade with 6dB dip in the middle suitable for smoothly fading in one track as the other fades out, to a very sharp response where the signal reaches full level within a few millimetres of the start of travel, suitable for fast cut or scratch mixing. Adjust as required.

Use the **REVERSE** switch to swap the CH1 and CH2 sides of the crossfader so that CH1 feeds the right hand side and CH2 feeds the left hand X side. Use this function if it better suits your mixing style.

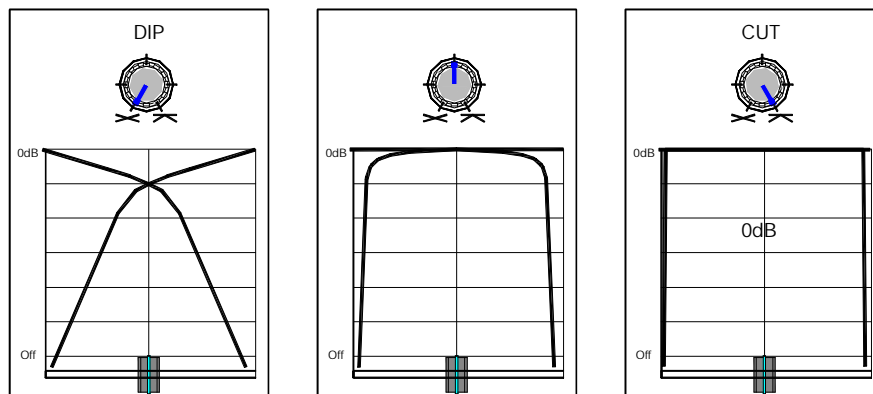

Using the Channel Faders

The two channel faders, also known as 'up faders', control the level of the music signal feeding the crossfader. They are part of the console VCA system and are used for performance in much the same way as the crossfader. They are not used to balance the level of one channel against the other as in a conventional live sound mixer. Instead, the fader is fully up (on) or fully down (off). It also provides dynamic level effects similar to the nimble fingered effects typically performed on the crossfader.

Use the **CONTOUR** and **REVERSE** controls in the same way as those associated with the crossfader to suit your mixing style. The fader scale is printed in two colours, blue showing normal scale and red showing reversed scale. The response is similar to that of the crossfader.

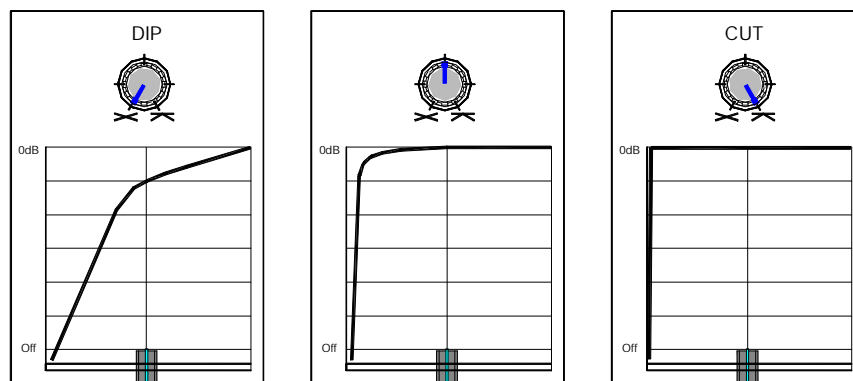

Replacing the Faders

The faders on a DJ mixer are heavily used and can suffer considerable wear and tear. The audio design using VCAs prevents clicks and scratchiness as the fader wears. However, the movement can become mechanically stiff or sloppy in time, or become ingrained with dirt. Should this be the case the fader may need replacement. The **XONE:02** channel faders and crossfader are removable and can easily be replaced in a few minutes. There are two versions available, the standard type and the higher grade Penny & Giles type. Make sure you order the correct version from your Allen & Heath dealer.



Before you start make sure you turn off the console and disconnect the mains power cord. The top plate must not be removed with power applied.

First prize off the fader knobs. Next, use a small cross-point (Pozidriv) screwdriver to undo and remove the 8 top plate screws. Lift the plate off to gain access to the fader assemblies. While supporting the fader with your fingers through the top opening unscrew the two fader mounting screws. Remove the fader assembly out of the console being careful not to damage any internal components. Unplug the cable from the old fader and plug in the new assembly. Check that the connector is correctly aligned and pushed on. Replace the assembly making sure the cable faces the front or left side of the console. Holding the new fader in position refit the mounting screws. Replace the top plate and fit the fader knobs.

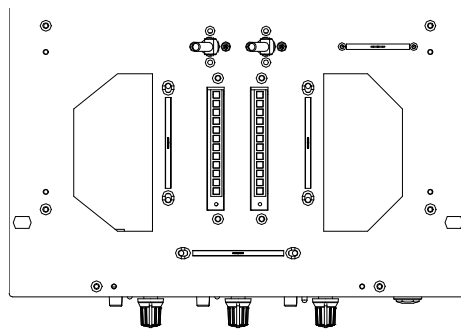

Make sure you replace the assembly with the correct fader type.

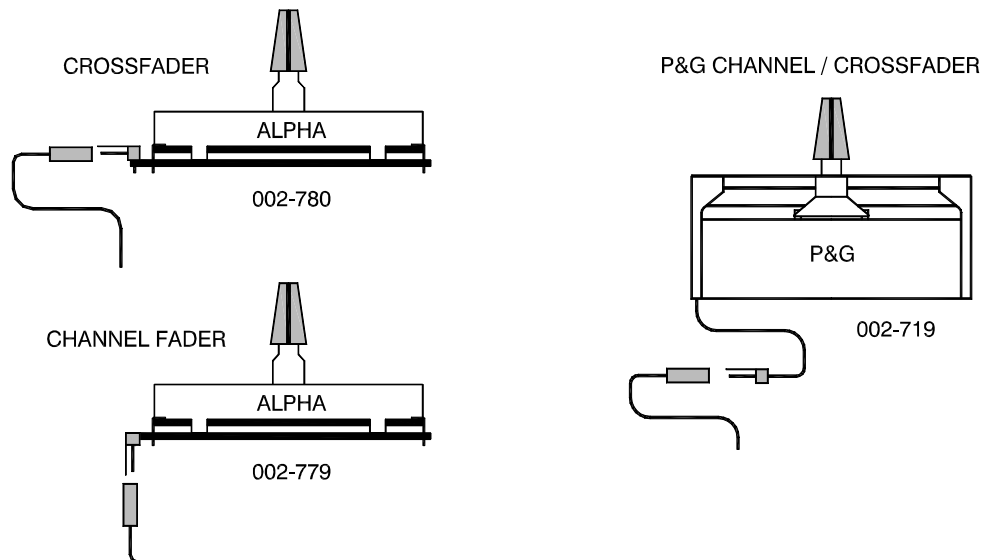

Repositioning the Transform Switches

The CH1 and CH2 TRANSFORM toggle switches can be repositioned to reverse their operation or rotate them to operate sideways.

Disconnect power and remove the console top plate as described above. Support the toggle switch with your fingers through the access hole while removing the switch mounting screws. Rotate the switch assembly into the new position required. Refit the screws into the appropriate holes. Replace the top panel.

Using Effects

You can patch in an external effects processor such as a sampler or echo unit. The **XONE:02** front panel EFFECT ON/OFF toggle switches let you punch the effect in and out of the music channels during performance. You can also route the microphone channel through the effects by pressing its EFFECT switch.

This routing is known as the 'effects loop'. Here's why:

When EFFECT is selected the signal is routed to the EFFECT SEND sockets on the rear panel instead of to the mix. Plug these into your stereo effects unit. The output of the effects unit should be plugged into the **XONE:02** rear panel EFFECTS RETURN sockets. These route the signal back to the mix after effects processing. The effects send is affected by the VCA MASTER LEVEL control. The effects return is not affected by this control.

If nothing is plugged into the EFFECTS RETURN sockets then the signal is routed through the normalising contacts of the TRS jacks back to the mix. In this case switching the effects in and out does not change the signal heard at the mix output.

Matching Effect Levels

The effects loop operates at 0dBu line level. It is important that the external effects unit operates at similar line level. Set its level trimmers for unity (0dB) gain through the device. If the effects gain is not unity then you may hear level differences as you switch the effects in and out.

The diagram below shows the signal path of the channel routed out to the effects device and back in to the mix. Also note the contacts in the TRS jack sockets that pass the signal through when nothing is plugged in.

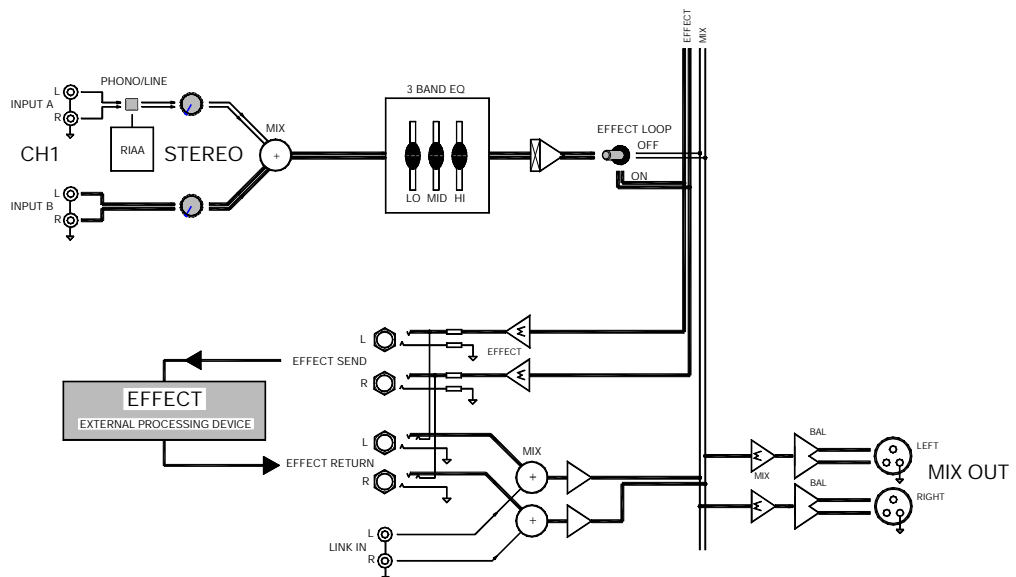

Using Channel Reverse

The summed INPUT A and INPUT B signals of CH1 and CH2 are fed to the CHANNEL REVERSE switch. Pressing this switch swaps these signals so that the CH1 input feeds the CH2 signal path and vice versa.

The channel faders and other performance controls have swapped position so you can now scratch on one turntable and operate the channel fader that controls the sound for the opposite deck using just one hand because that fader is more within reach. For example, you could have your small finger on the left turntable and thumb on the fader. It is all about positioning the controls for the sounds playing just where you want them. It puts the controls of the opposite deck more in reach of the DJ. And it gives you the edge when doing battle!

Quite a new feature, but then creativity is what mixing is all about...

Specifications

0dBu = 0.775 Volts rms, +4dBu = 1.23V rms 0dBV = 1 Volt rms, -10dBV = 316mV rms

Max output level	XLR	+23dBu into >2k load	Mix System	VCA	
	TRS	+21dBu into >2k ohm		Music EQ	3-Band +6/-26dB 100Hz, 1kHz, 10kHz 12dB/oct slope
	RCA	+15dBu into >10k ohm		Mic EQ	3-Band +/-12dB 120Hz, 2.5kHz, 6.5kHz
Headroom	Channels	+21dB	Channel Faders	45mm stereo VCA Dual rail, gold contacts Replaceable Penny & Giles option	
	Mix to output	+23dB		Crossfader	45mm stereo VCA Dual rail, gold contacts Replaceable Penny & Giles option
Freq response	+0/-1dB 10Hz to 30kHz		Transform	Fast action toggle Rotatable	
Distortion	< 0.04% THD+N @1kHz +10dBu				
Crosstalk	< 90dB Channel shutoff @1kHz				
MIC EIN 22-22kHz	-128dB	150 ohm source			
Residual noise	< -88dBu				
Mix noise	< -81dBu				
Meters	Peak reading 12 led -30 to +9, +15 (PK)				
Mic Peak	Within 6dB of clipping				

Power Supply

Internal switch mode power unit with auto sensing mains input.

MAINS IN socket	IEC 3 pin
Power lead	Country dependent with moulded mains plug supplied
AC mains	100 to 240V AC @ 50/60Hz
Consumption	30W max
Mains fuse rating	100-240V AC T500mA 20mm

Dimensions and Weights

The console is fitted with rubber feet for desktop operation. It also has integral rack ears so that it can be fitted into a plinth, rack or other equipment furniture. Note that it is narrower than the standard 19" equipment rack system. Use M6 screws with plastic protective cups to mount the console into the furniture.

	Width	Height	Depth	Weight
Unpacked	262 mm (10.3")	90 mm (3.5")	320 mm (12.6")	4.5 kg (10 lbs)
Packed	475 mm (18.7")	210 mm (8.3")	395 mm (15.6")	5 kg (12 lbs)

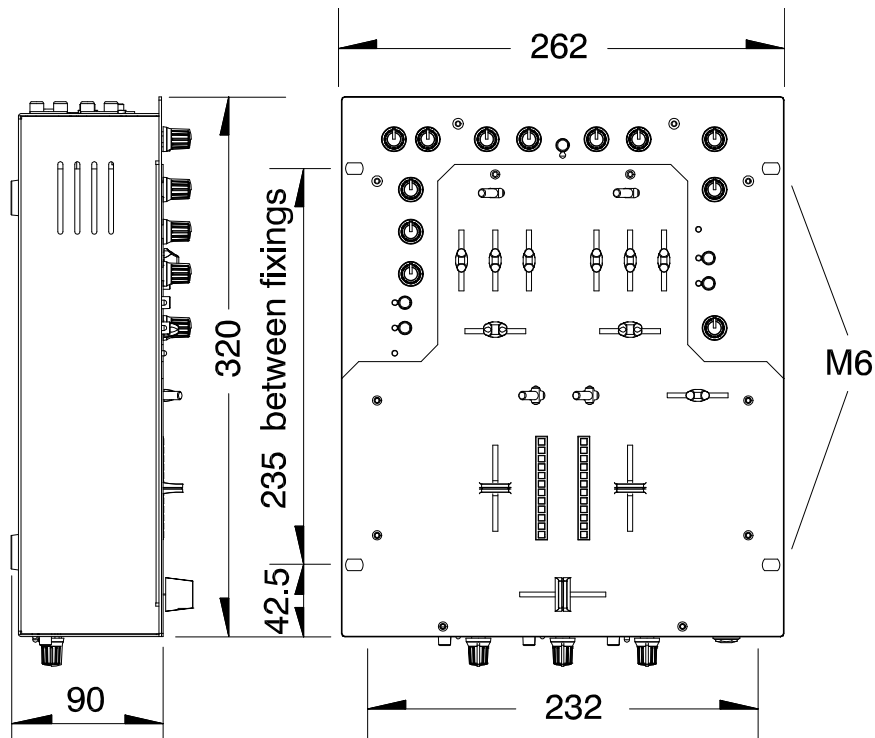

XONE:02 BLOCK DIAGRAM

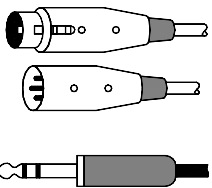
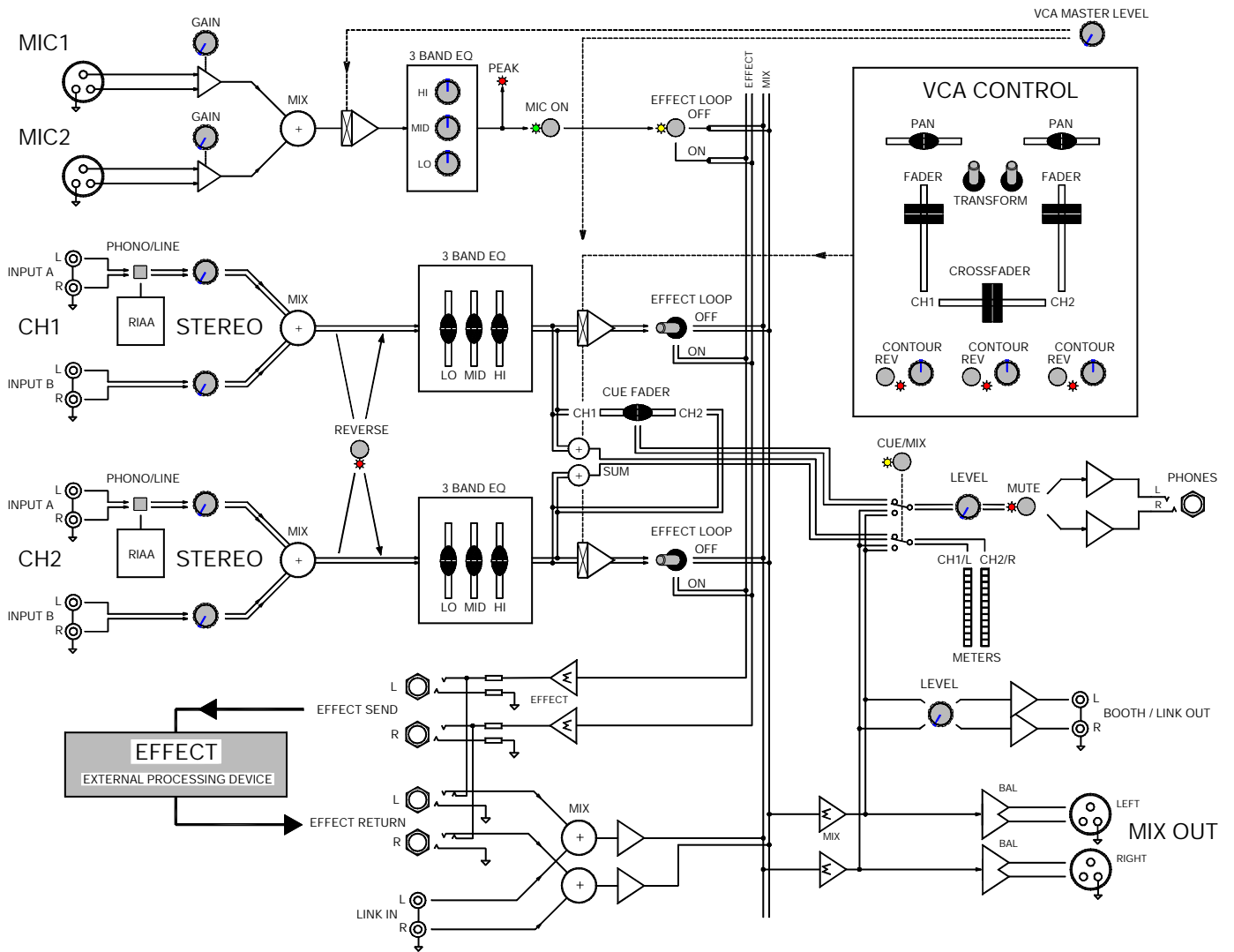

Connector Types

XLR connector : Pin 2 = hot (+) Pin 3 = cold (-) Pin 1 = GND
 TRS input and output connectors : Tip = hot (+) Ring = cold (-) Sleeve = GND
 RCA PHONO pin connectors

Input Connections

	Type	Impedance	Sensitivity
MIC IN	Balanced XLR female	2k ohm	-50 to -10dBu
Stereo LINE IN	RCA phono	>10k ohm	-22 to +15dBu
Stereo PHONO IN	RCA phono RIAA	47kohm/330pF	2 to 140mV
EFFECT RETURN	TRS jack	>10k ohm	0dBu
LINK/BOOTH IN	RCA phono	>10k ohm	0dBu

Output Connections

	Type	Impedance	Level
MIX OUT L,R	Electronically balanced TRS jack	<75 ohm	0dBu
LINK/BOOTH OUT	RCA phono	<75 ohm	0dBu
EFFECT SEND	Impedance balanced TRS jack	<75 ohm	0dBu
HEADPHONES	Tip = L Ring = R	30 to 600 ohm, 70 ohms recommended	

Glossary

The following section is included to help you understand some of the technical terms and jargon referred to with consoles of this type. It is by no means a complete reference. Please refer to specialist audio publications should you wish to know more.

Amplitude Another term used for signal level.

Asymmetric EQ An equaliser with a different amount of cut and boost of the frequency bands. This is used to restrict the available boost so preventing system overload while providing extended cut to allow dramatic performance effects by 'killing' selected frequencies.

Attenuate Reduce the signal level.

Aux Auxiliary. An independent mix derived from the channels for various functions. This can be set pre (before) or post (after) the channel fader. Pre-fade sends are often used for foldback monitor feeds. Post-fade sends are often used for sampler, reverb and other effects, zone and special recording feeds.

Balanced, Unbalanced Refers to the type of input or output signal connection. An unbalanced connection has two signal carrying conductors, one of which is the cable shield. A balanced connection has three conductors, two for signal and a shield which is connected to earth. Because the signal conductors are at the same impedance and of opposite polarity they are better able to cancel and therefore reject interference and noise pickup. It is standard practice to use balanced connections for long cable runs, for example to amplifiers, or cables carrying sensitive or low level signals, for example microphones.

Battle Mixing The competitive sport where DJs try to kill each other with their performance...

Beat Mixing Using the variable pitch controls on turntables/CD players to synchronise the rhythm track of two separate songs, so that the beat remains constant when smoothly cross-fading from one to the other.

Bi-amping Providing separate amplifiers to drive the high and low frequency units in a loudspeaker. This requires a crossover processor that splits the frequency band into low and high. Bi-amping usually produces a cleaner and more controllable sound in larger systems.

BPM Beats Per Minute. The measurement of the rhythmic beat or tempo of the music.

Booth The area, often enclosed, where the DJ operates. Usually provided with local booth monitor loudspeakers.

Cardioid The response of a microphone which is more sensitive in front than behind. This is generally used for vocal miking to reduce acoustic feedback.

Cartridge The pickup in a turntable. Uses a needle to pick up vibrations from the record (vinyl) and convert this to electrical signals that feed the console. The cartridge is usually fitted to a removable headshell that plugs into the turntable arm.

Clipping The harsh distorted sound that results when the signal hits the maximum level possible. This is set by the power rail voltage. Above this there is simply no more voltage available so the signal is 'clipped'.

Compact Disc (CD) Well established stereo player using digitally mastered pre-recorded flat discs. Becoming popular with DJs as a replacement or alternative to vinyl mixing. Recordable CDs are now available.

Contour The term used to describe the 'law' of a fader, how quickly it responds as it is moved, or the amount of fade per unit of movement. The contour control associated with a crossfader lets the DJ tailor its response to suit the preferred mixing style.

Crossfader A short horizontally mounted fader for smoothly fading one music track in while fading the other out. Often used by the DJ for cutting and layering sounds while mixing.

Cue A monitor system provided for the DJ or console operator to check individual channel signals using headphones while lining up tracks ready to introduce into the mix. This does not affect the main console outputs.

Cut Mixing Moving the cross-fade control sharply from one side to the other, to either pick out a sound, a hi-hat, kick drum etc, or to drop straight into another record. Also known as chopping.

DAT Digital Audio Tape. A type of digital 2 track recorder that uses a small tape cartridge to produce high quality recordings in a compact format.

dB Decibel. The unit of measurement for audio signal level. This is logarithmic to follow the response of the human ear. 'dB' is a relative measurement to compare one level with another, for example gain from input to output. 'dBu' is an absolute measurement referenced to a voltage standard where 0dBu = 0.775V rms. The console main outputs operate at 0dBu = '0' reading on the meters. 'dBV' is a similar measurement but refers to a 1V standard. It is common for consumer equipment to operate at the 'low' standard of -10dBV (316mV). 'dBA' refers to sound pressure level and is measured using the 'A' scale that 'hears' in the same way as the human ear.

dB/octave Term used to specify the slope of an EQ (equaliser) response. This is how quickly it cuts or boosts relative to frequency.

DJ Disc Jockey. The console operator sequencing and playing the music tracks. Some simply play the tracks, others talk over with introductions and announcements, and others provide an entertaining performance by mixing and shaping sounds to create a completely different musical experience.

Drum Machine An electronic drum simulator as used by keyboard players and in electronic music. This now provides another DJ tool to create an alternative beat to mix in with the music.

Dynamic Range The difference expressed in dB between the highest and lowest signal levels possible. This is limited by the clipping level and residual noise floor respectively.

Earth Also known as 'ground'. The term for the electronic signal reference. This connects to the mains supply earth point and all cable shields and

conductive equipment cases. It provides the return for the signal voltage within the equipment. It also ensures operator safety by removing the possibility of electric shock should the mains voltage touch any metal part.

Earth (ground) Loop The result when the equipment sees more than one path to the system earth. Current flows because a resistive loop susceptible to radio and mains interference is formed. In severe cases this can result in audible hum or buzz in the system. Breaking the loop by removing all but one path to earth usually solves the problem.

Effect Loop The signal path associated with patching in an external effects processor such as sampler or echo unit. The signal is routed to the effects send instead of direct to main mix. It is returned through the return input back into the mix. The **XONE:02** lets you switch the effects in or out during performance.

Equaliser (EQ) This provides cut or boost of selected frequencies (equalisation) for tonal shaping of the sound. This is similar to the bass and treble controls of domestic hifi amplifiers. However, **XONE:02** provides 3 independently controllable frequency bands for corrective or effective sound shaping.

Feedback Also known as 'howlround' or 'ringing' this is the rapidly increasing tone produced when a microphone picks up its own signal from the speakers. It is usually a shrill and annoying squeal that should be quickly dealt with by repositioning the microphone or speakers, reducing mic gain or equalising the system to notch out the offending frequencies.

Gain This is the boost or attenuation applied to the source signal in the channel preamp stage to match it to the console operating level. For example, a large amount of gain is needed to match low microphone signals. It is set using the console meters. Gain is not used for level (volume) control.

Ground See 'earth'.

Hamster The popular term for reversing crossfader program. The **XONE:02** does this using the channel reverse switch.

Headroom The amount of level available expressed in dB to handle peaks above the normal 0dB operating level.

Hz Hertz. The measurement of frequency. The audio spectrum ranges from a low (bass) frequency of 20Hz to a high (treble) 20kHz. Not many sound systems reproduce the full range. Average hearing does not extend much beyond 15kHz or so. Response is further impaired if the ear is subjected to continual high sound pressure levels.

Hum Apart from not knowing the words... this is the audible noise that usually results from mains interference pickup, earth loops, bad interconnections and induced power supply and lighting fields. It is usually at mains frequency (50/60Hz) or a related harmonic.

Impedance (Z) A technical term for the resistance of a signal conductor to ground. Low impedance usually refers to microphones of 200 ohms or less, and line signals typically less than 100 ohms. Low Z sources are less prone to interference pickup. Inputs are usually high impedance so that one source can connect to more than one channel without signal loss. Note that the operating impedance of a connection is set by the impedance of the source, not that of the unconnected input.

Impedance balanced Refers to the type of output signal connection. It has three conductors, two for signal and a shield which is connected to earth. Provides interference rejection similar to a fully balanced connection because the two signal conductors are matched at the same impedance. However, the drive capability is less because the signal is carried by only one conductor.

Limiters A signal processor that limits the maximum level possible by preventing the signal going over a predetermined threshold level. This is very useful in club installations where it is inserted between the console and house system amplifiers to prevent the DJ exceeding the maximum allowable volume.

Link In and Out Lets you plug the output of one console top the input of another for battle mixing.

MC Master of Ceremonies. The presenter who introduces the performances and maintains the running order. Also refers to a rapper who talks in time to the beat.

MiniDisc A type of low cost digital 2-track recorder that uses a disc similar to but smaller than that used by computers. It uses a compression algorithm and is able to record up to 74 minutes of stereo material. It is regarded as the modern replacement for the audio cassette recorder. It has the added facility to label and edit tracks.

Mono A single source with no stereo content, or the left and right stereo signals summed together as one.

Mute To turn off the signal. Transform is a mute effect.

Noise Generic term for an unwanted signal. This may be residual electronic hiss, hum, buzz, clicks and pops, or simply loud undesirable music.

Noise Floor This is the term for the residual electronic noise produced by all powered audio equipment. It usually sounds like a constant hiss, although some equipment may suffer from residual hum as well.

Omni-directional The response of a microphone which picks up sounds equally all round. Not suited to live vocal applications as they are more prone to feedback.

Pan Panoramic. A control that adjusts the balance of the signal in the left and right speakers. Can be used to create dynamic performance effects.

Peak Meter A type of signal meter that has a very fast attack and slower release. This picks up the fast signal transients and holds them long enough for the operator to see the activity on the display. These meters typically use led (light emitting diode) displays.

Phantom Power The DC voltage required by certain microphones to power the capsule. These are usually sensitive studio grade mics not suited to DJ mixing. The power is provided by the console using the two signal conductors in the balanced connection. There is no provision on **XONE:02** for this type of microphone.

Phono Abbreviation for phonograph as in 'turntable'. Usually means RIAA equipped input when marked on console inputs. Can also refer to the RCA 'phono' type pin jack connector found on turntables, CDs and much domestic equipment.

Polarity Sometimes referred to as 'phase' this is the + / - sense of a balanced signal or loudspeaker

connection. Reversed polarity should be avoided and checked for as it can cause uncomfortable phasing effects as the listener moves between the speakers.

Punch Performance effect popular with DJ's. Pressing a button next to the crossfader punches in (turns on) the opposite track.

Reverse Associated with the fader this swaps its top and bottom ends so that it is fully on when pulled back and off when up. Associated with the input channels this swaps the channel signals to associate each with the opposite controls. These functions provide greater performance flexibility to suit different performance styles.

RIAA Record Industry of America Association, responsible for the long established equalisation standard that is applied to the signal produced by a turntable cartridge. Due to the physics of vinyl reproduction the needle produces a reasonable high frequency signal but much less low frequency. An RIAA pre-amplifier compensates for this by inversely attenuating the high and boosting the low frequencies.

Reverberation The way in which sound reflects and bounces around the room after the source is removed. This depends on the size and shape of the room as well as the materials such as carpets, curtains and clothing that absorb certain frequencies.

RPM Revolutions Per Minute. The measurement of turntable speed, eg. 33, 45 RPM

Sampler Another performance effect popular with DJs. The channel signal is sent to a digital processor that samples (stores) a short duration of sound. The output is returned through the effects loop return and replayed by pressing a trigger. Many samplers provide creative effects such as repeat and reverse.

Scratch Mixing The art of rhythmically rocking a record back and forward on a turntable, to repeat a certain sound, a vocal or tone, at the same time operating the cross-fader to create a syncopated "wah wah" chirp added over a bass heavy back beat.

Signal-to-Noise Ratio (SN) This is the difference expressed in dB between the normal 0dB operating level and the residual noise floor. It represents how far above the equipment hiss level the signal operates. More is better.

Slip mat A fabric turntable mat positioned under the record so that the DJ can hold it stationary ready to let go for a fast start at the point cued.

Sound-to-Light A processor that converts an audio signal into a control voltage that triggers lighting

effects. This produces the popular disco effects with lights flashing in time to the beat.

Sub Bass A loudspeaker designed to reproduce only very low frequency sound, typically from around 30 to 120Hz. A crossover is used to route only the low frequencies to the sub.

Tempo The rhythmic beat of the music, usually referred to in BPM (Beats Per Minute). The DJ can tap the tempo into the LFO so that its speed is in time with the music.

Transform Performance effect popular with DJ's. Pressing a button next to the crossfader mutes (turns off) the active music. Used for 'stutter' effects.

TRS Jack Refers to the 3-pole (stereo) ¼" jack plug with Tip, Ring and Sleeve connections.

TS Jack Refers to the 2-pole (mono) ¼" jack plug with Tip and Sleeve connections. TS cables can plug into the **XONE:02** impedance balanced outputs without modification.

Turntable Also known as the 'Ones and Twos' or 'Wheels of Steel' or more conventionally a 'record deck' this plays vinyl discs, still the most popular source for DJ mixing. It is common for the cartridge to plug directly into the mixing console 'phono' input which provides the RIAA equalisation required. The turntable usually has variable speed control so that the DJ can synchronise the beat between tracks.

Up Fader Another term for the channel fader.

VCA Voltage Controlled Amplifier. An audio gain element whose level is controlled by a remote DC voltage rather than through a fader or rotary control.

VCA Crossfader Functions as an audio crossfader but with the audio level controlled by a DC voltage produced by the fader. This voltage can be electronically filtered and is therefore able to remove the clicks, scratches and drop-outs associated with worn audio faders.

VCF Voltage Controlled Filter. An audio filter whose cut-off frequency is controlled by a remote DC voltage rather than a rotary or switched control. This provides greater range and capability. This is available on other **XONE** consoles and is used to produce the dramatic sound of the classic analogue synthesiser filter.

XLR The professional standard 3 pin round connector used for microphone and other balanced connections. Equipment female sockets are for inputs, male for outputs.

Order Codes

The following products and parts can be ordered from Allen & Heath or the approved dealer:

XONE:02/v	XONE:02 2 channel DJ scratch mixer	/v = specify voltage
XONE:32/v	XONE:32 3 channel DJ mixer	/v = specify voltage
XONE2:62/v	XONE:62 6 stereo channel mixer	/v = specify voltage
XONE2:464/v	XONE:464 4 mic 6 stereo channel mixer	/v = specify voltage
02-779	45mm Stereo Channel Fader for XONE:02	
02-780	45mm Standard Crossfader for XONE:02	
002-719	Optional P&G crossfader for XONE:02,32, 62 & 464	

Tips and Troubleshooting



For your safety do not remove the **EARTH** (ground) connection in the power lead of the console or connected equipment.



Have your **MAINS SYSTEM** checked by a qualified electrician. If the earthing is solid to start with you are less likely to experience problems.



Use high grade **AUDIO CABLES** and check them for reliable connection. It is well known that many audio system problems are due to faulty cables and connectors.



In a club or similar installation strict **SOUND LEVEL** and noise regulations may apply. Check that your system levels are correctly set up to comply.



To avoid damage to your hearing start with the **HEADPHONES** level control at minimum and turn up only as much as is needed to maintain comfortable listening level. Do not drive headphones at high listening levels for long periods of time.



Always switch connected **AMPLIFIERS** on last and off first to avoid thumps when the console and connected equipment is turned on or off.



Reduce level if the red meter **PEAK** led flashes. These warn you that you are near clipping which may result in system overload and distortion. The **XONE:02** provides plenty of drive and headroom when operated around the 0 to +6 meter points. Check that the amplifier / speaker system is correctly matched and set up for correct levels.



If you suspect a console fault. The console is the heart of the audio system and is often suspected faulty when a problem occurs. Usually the fault is found to be with other equipment in the system, typically the interconnecting leads, input sources, or level matching between equipment. Check for source problems by unplugging each channel in turn listening for a change in symptom. To check the console, isolate it by unplugging all sources and outputs leaving just headphones and a reference source such as a CD player connected.



I have plugged in a microphone but it does not work. The **XONE:02** is designed to operate with non-phantom powered dynamic microphones such as the popular vocal types. Do not use microphones which require phantom power. If it has an on/off switch check that it is turned on. Make sure the front panel **LEVEL** control is turned up and **MIC ON** switch pressed.



The signal sounds very distorted with high level and excessive bass. Only plug turntables needing RIAA equalisation into the **PHONO** inputs with RIAA selected.



There is a hum on the turntable channels.

Check that the turntable earth strap has been correctly connected to the console chassis earth post. Also check that the turntable headshell and cartridge are correctly aligned and plugged in.



The MIX meters reads fine but the signal is distorted. Switch the meters to **CUE** and check that the channels are not peaking red. If they are, the output meter may still read fine if the fader or master level control is not set fully up. Reduce the input level control if the channel meter reads too high.



Only one side of the stereo mix is working.

Check that the **VCA PAN** control is not set fully to either L or R. Also check for bad connections, in particular **RCA phono** leads and turntable headshell and cartridge pins.



The channel is not working. Check that the **TRANSFORM** switch is not selected. This mutes the channel.



There is feedback. Check that the microphone is not placed next to the headphones or loudspeakers. The mic may pick up its own signal and feed back. Use the mic EQ to tune out the range of frequencies likely to feed back. In loud listening conditions feedback can sometimes be caused by mechanical vibration through the turntables into the cartridge, or even the needle resting on a cued turntable starting to resonate in the groove of the record.



The crossfader works backwards. Check that the reverse switch has not been pressed and its red LED on. If it is off then check that the crossfader has been re-fitted the right way round if previously removed.



I have connected a stereo source to a single input using a Y-adaptor but it sounds bad. Do not connect more than one output to the input. These adaptors are designed to feed one output to two inputs, not the other way round.



The level changes when I switch in the effects. The effects loop operates at 0dBu line level. Make sure the external effects device is set for similar line level and 0dB unity gain.



I can hear interference pickup in the mix. If you are not using the **LINK IN** sockets then make sure the shorting plugs supplied with the console are plugged in. These short out the inputs to prevent interference when not in use.

Check out my Internet site :

<http://www.xone.co.uk/>