

ALLEN & HEATH

XONE VF-1



User Guide

For standard version VF-1 and RIAA version VF-1R

Publication AP5917

XONE VF-1 User Guide AP5917 Issue 2

Copyright © 2004 Allen & Heath Limited. All rights reserved

Whilst we believe the information in this guide to be reliable we do not assume responsibility for inaccuracies. We also reserve the right to make changes in the interest of further product development.

 This product complies with the European Electromagnetic Compatibility directives 89/336/EEC & 92/31/EEC and the European Low Voltage Directives 73/23/EEC & 93/68/EEC.

This product has been tested to EN55103 Parts 1 & 2 1996 for use in Environments E1, E2, E3, and E4 to demonstrate compliance with the protection requirements in the European EMC directive 89/336/EEC. During some tests the specified performance figures of the product were affected. This is considered permissible and the product has been passed as acceptable for its intended use.

Allen & Heath has a strict policy of ensuring all products are tested to the latest safety and EMC standards. Customers requiring more information about EMC and safety issues can contact Allen & Heath.

NOTE: Any changes or modifications to the unit not approved by Allen & Heath could void the compliance of the unit and therefore the user's authority to operate it.

ALLEN & HEATH

Manufactured in the United Kingdom
Allen & Heath Limited
Kernick Industrial Estate, Penryn, Cornwall, TR10 9LU, UK

<http://www.allen-heath.com>



Important Safety Instructions – Read First

- Read instructions:** Read and retain these instructions for future reference. Read the instructions on the Safety Sheet provided separately. Adhere to all warnings printed here and on the console and its power unit.
- Cover:** Operate the unit with its cover correctly fitted. Refer servicing work to competent technical personnel only.
- Mains power:** Connect the unit to a mains power supply only of the type described in this user guide and marked on the unit. The power source must provide a good ground connection. Do not remove or tamper with the ground connection in the power cord. Use the power cord with sealed mains plug appropriate for your local mains supply as provided with the unit. Route the power cord so that it is not likely to be walked on, stretched or pinched by items placed upon or against it.
- Installation:** Install the unit in accordance with the instructions printed in this user guide. Do not connect the output of power amplifiers directly to the unit. Use audio connectors and plugs only for their intended purpose.
- Ventilation:** Ensure adequate ventilation around the unit. Do not obstruct the ventilation slots or position the unit where the air flow required for ventilation is impeded.
- Moisture:** To reduce the risk of fire or electric shock do not expose the equipment to rain or moisture or use it in damp or wet conditions. Do not place containers of liquids on it which might spill into any openings.
- Environment:** Locate the unit away from direct sunlight and any equipment which produces heat such as power supplies, amplifiers and heaters. Protect from excessive dirt, dust, heat and vibration when operating and storing. Avoid tobacco ash, drinks spillage, and smoke, especially that associated with smoke machines.
- Handling:** To prevent damage to the controls and cosmetics avoid placing heavy objects on the unit surfaces, scratching the surface with sharp objects, or rough handling and vibration. Protect the controls from damage during transit. Use adequate packing if you need to ship the unit.



Important Note on Mains Voltage Setting

The internal power unit has a universal mains voltage input able to operate within the range 100V to 240V.AC 50/60Hz. Ensure that your local mains voltage is within this range. Check that you have been supplied with an IEC mains lead fitted with a moulded mains plug suitable for your local supply.



Important Mains Plug Wiring Instructions

The unit is supplied with a moulded mains plug fitted to the AC mains power lead. Follow the instructions below if the mains plug has to be replaced.

The wire which is coloured Green/Yellow or Green must be connected to the terminal in the plug which is marked with the letter E or with the Earth symbol.

This appliance must be earthed.

The wire which is coloured Blue or White must be connected to the terminal in the plug which is marked with the letter N.

The wire which is coloured Brown or Black must be connected to the terminal in the plug which is marked with the letter L.

Ensure that these colour codes are followed carefully in the event of the plug being changed.

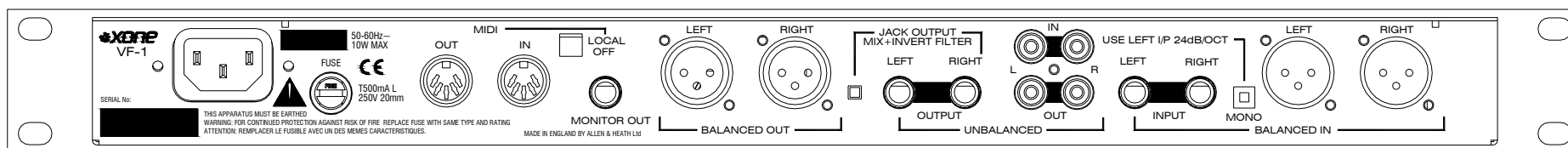
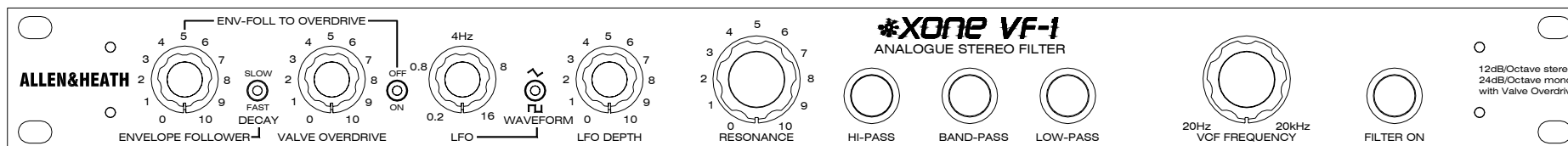

Welcome to the

The **XONE VF-1** is a high quality 1U rack analogue filter unit featuring an enhanced version of the legendary VCA filter circuit used in our award winning **XONE** mixer range.

Three different **filter types** are provided, high-pass, band-pass and low-pass. These can be selected together to create further types, for example high-pass and low-pass together produce a notch filter. The filter **frequency** can be swept either manually or automatically in several different ways to create stunning or subtle performance effects.

A **resonance** control adjusts the sharpness of the filter from a gentle roll off to a peaky maximum reminiscent of the distinctive sound of the classic analogue synthesiser. The ARC (automatic resonance control) monitors the output of the filter to automatically reduce the resonant peaks of high level signals so avoiding potentially system damaging transients. For further protection all the filter controls are “soft switched” to prevent clicks during performance.

Using a rear panel switch the filter can be configured as **2-pole** stereo 12dB/octave or **4-pole** mono 24dB/octave without the need to re-patch. Another rear panel switch can sum the inverted filter signal with the non filtered input to create **cancellation effects** providing some unusual and subtle sounds, especially when routed to an external effects unit such as reverb or delay.

As well as the VCA filter the **VF-1** also features a **valve** (tube) input stage with drive control. The signal level through the valve can be

progressively increased to create musically pleasing second harmonic distortion. This is a great tool for adding warmth to a mix or for fattening up thin bass sounds. Automatic gain reduction circuitry maintains a near constant output level as the overdrive control is increased.

An **envelope follower** with switchable release time allows the filter cut-off frequency to be modulated by the intensity of the input signal. This can be used to create some interesting effects, particularly with drum loops and bass lines, or be switched into the valve circuit to give intensity modulated overdrive.

A wide range **LFO** (low frequency oscillator) with square/triangle waveforms completes the modulation toolbox for the filter system.

The **VF-1** can send and receive **MIDI** allowing the filter frequency, type and on/off status to be remotely controlled or saved to a sequencer. It can be configured to operate in several different modes to interface to our MIDI equipped Xone:92 DJ mixer, a sequencer, or to track the filters to MIDI notes.

The **VF-1** is equipped with a wide range of input and output connectors including balanced XLR, TRS jack and RCA phono with optional RIAA preamp, making it easy to connect to almost any system. A dedicated monitor output is provided to allow the filtered sound to be previewed before switching in the effect.

Whether you are a serious DJ or a professional production studio we hope you enjoy using the uniquely powerful **XONE VF-1**.

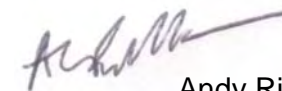

Andy Rigby-Jones, the designer

Front Panel Controls

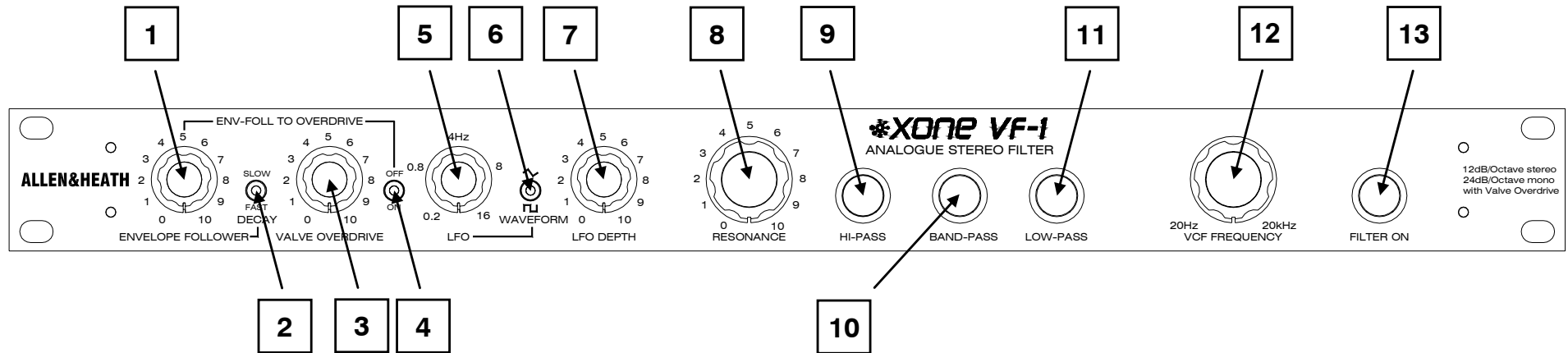

1 Envelope Follower

The envelope follower modulates the filter cut-off frequency in direct proportion to the intensity of the input signal. For example, with low-pass filter selected and set to a low 20Hz, turning up the envelope follower will produce a dynamic effect as the filter cut-off frequency rises and falls along with the loudness of the music.

2 Envelope Follower Decay

Sets the decay speed of the envelope follower, either slow or fast. This changes the sound of the effect according to the type of music played.

3 Valve Overdrive

Turn this up to increase the amount of signal passing through the valve (tube) stage. This increases the second harmonic distortion and valve compression effect created which produces a pleasing 'fattening' of the sound. At minimum the signal is low enough to ensure that the valve is operated in its linear region with little effect. Continuing to increase the level of overdrive will first cause the valve to "soft clip", ideal for music sources, and then bring in "hard clip" circuitry making the effect much more pronounced, better suited to changing the character of instrument sounds such as a bass line. The control includes a 'make-up gain' element which controls the ratio between input and output level so that the volume does not seem to increase too much as the overdrive, and therefore distortion/compression effect, is increased.

4 Envelope follower to overdrive

Enables the envelope follower circuit to modulate the valve overdrive so that the valve distortion/compression effect increases dynamically with the music. Produces a subtle, interesting effect..

5 LFO Speed

Sets the speed at which the LFO (low frequency oscillator) will modulate the filters, from a slow 0.2Hz (approximately 12BPM) to a very fast 16Hz (960 BPM).

6 LFO Waveform

Selects the type of waveform that the LFO outputs to modulate the filter. A triangle output will smoothly sweep the filter cut-off frequency up and down, whilst a square wave will produce an instant cut-off frequency change rather like a “gating” effect.

7 LFO Depth

Adjusts the level (or depth) of LFO modulation. Set anti-clockwise for no effect, turn clockwise to increase the effect.

8 Resonance

The resonance control alters the way the filter behaves at its cut-off frequency. With the control at minimum the filter will have a gentle roll-off and therefore a smooth, subtle sound. At maximum the filter will have extra gain at its cut-off frequency, greatly emphasising any sound at this frequency.

Care should be taken when using the filter unit with the resonance set at maximum as it may cause clipping in the signal path. However the **VF-1** includes an automatic resonance control (ARC) circuit that reduces the amount of resonance at high signal levels so minimising the likelihood of distortion. Also, the ARC circuit will automatically reduce the amount of resonance at low frequencies where there is higher energy level and therefore greater chance of damage to low frequency speaker drivers.

When the two **VF-1** filters are combined as a single mono 24dB/oct unit the amount of resonance will be doubled.

The diagram below shows the effect around the filter cut-off frequency of increasing the resonance.

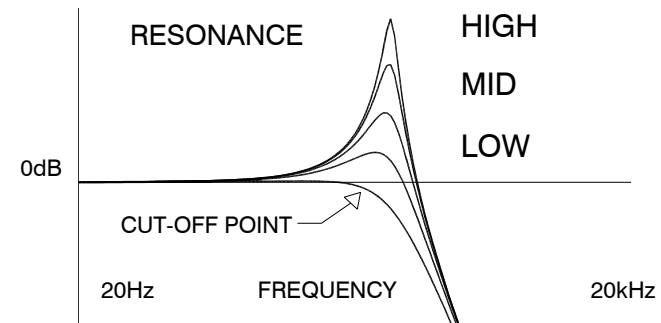

9

Hi-Pass

Turn on the high-pass filter to progressively remove low frequencies below the cut-off selected using the VCF FREQUENCY control [12]. The switch illuminates when the hi-pass filter is active. The diagram shows the response as the frequency control is rotated. It also shows the boost around the cut-off frequency when resonance is increased.

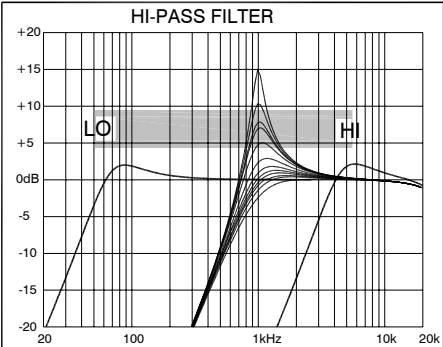

10

Band-Pass

Turn on the band-pass filter to progressively remove frequencies above and below the cut-off selected using the VCF FREQUENCY control [12]. The switch illuminates when the band-pass filter is active. The diagram shows the response as the frequency control is rotated. It also shows the boost around the cut-off frequency when resonance is increased.

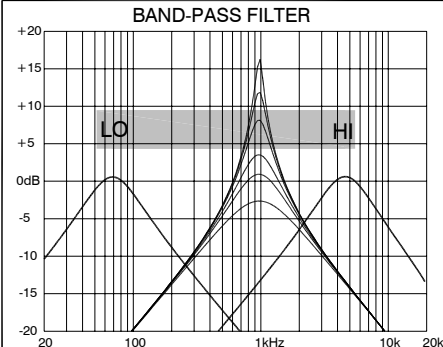

11

Lo-Pass

Turn on the low-pass filter to progressively remove high frequencies above the cut-off selected using the VCF FREQUENCY control [12]. The switch illuminates when the low-pass filter is active. The diagram shows the response as the frequency control is rotated. It also shows the boost around the cut-off frequency when resonance is increased.

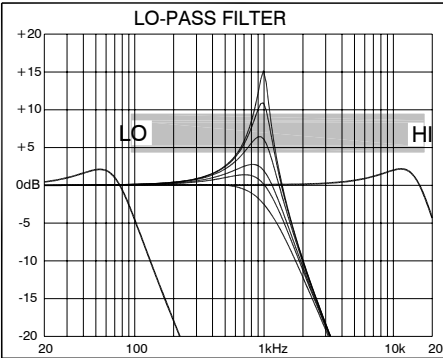

12 VCF Frequency

Sets the cut-off frequency of the filter from 20Hz (fully anti-clockwise) to 20kHz (fully clockwise). This lets you sweep the frequency across the full audio range to create dramatic performance effects.

13 Filter On

Press this switch to route the audio signal through the valve overdrive and filter circuits. In the off mode the signal bypasses the filter and valve stages and is routed directly from input to output at unity gain. When selected the switch illuminates.

The filter ON switch is also 'soft switched' so that it can be used during performance to switch the filter in or out without audible clicks.

Note: With no filter type selected the audio signal is muted (turned off).

Using the Filters

The three filter select switches are 'soft switched' and therefore will not produce any transient clicks when switched. This means the filters can be seamlessly switched in and out during performance to create the required effects.

The filters can be used as a mix aid or an effect. For example, you can introduce a track by sweeping the Hi-pass filter anti-clockwise from high to low to gradually add the mid and low music energy. You can also introduce the bass beat of a track using the Low-pass filter to gradually bring in the higher frequency definition of the music. Sweeping a resonant filter across or in time with a track can add a unique effect to a performance. Using the filters with a bass line or an instrument can add a new dimension to its sound. Experiment with the Envelope Follower and LFO too.

More than one filter type may be selected at the same time. Simply press two or more switches simultaneously. The selected filter switches illuminate to show they are active:

Notch – Combine Hi-pass and Low-pass. Used with low settings of RESONANCE you get a phasing effect as a small range of frequencies is removed. Try sweeping the effect across the full audio frequency range.

All pass – Combine Hi-pass, Band-pass and Low-pass. A surprising effect considering that all frequencies are 'passed'. However, the filter type interaction around the cut-off point creates an interesting effect that varies from subtle to dramatic depending on the setting of the RESONANCE control.

Try playing different types of music and experiment with the controls. The creative possibilities of the **VF-1** are limited only by your imagination...

Rear Panel Controls

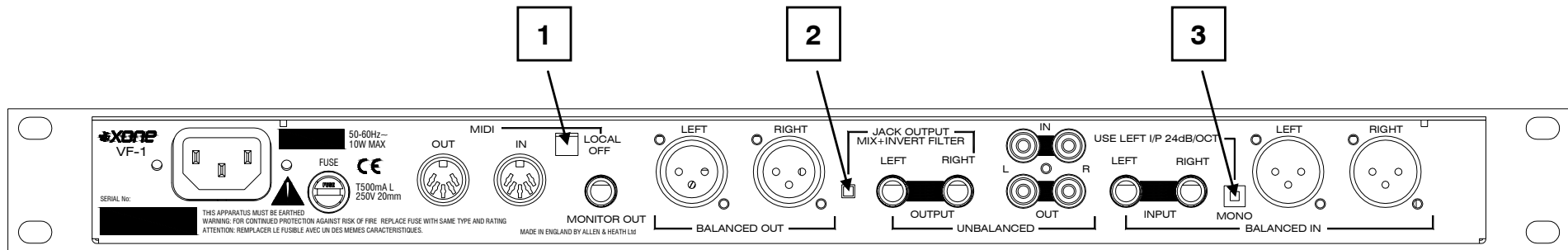

1 Local Off

To enable the unit to receive MIDI the local OFF switch must be selected. This switch also re-routes the front panel VCF Frequency control to control the filter via the MIDI processor rather than direct..

2 Mix+Invert filter

Mixes the inverted (polarity reversed) filter signal and the unfiltered input signal together and sends the difference to the TRS jack output. Create some interesting effects by feeding this signal through an effects unit and then mixing it back with the original in a mixing console.

3 Mono

Switches the unit from 12dB/oct stereo to 24dB/oct mono.

In the normal stereo position, two valve overdrive/filters are provided, one for the left signal, the other for right. Each filter has a 12dB per octave slope.

When pressed the two are combined internally in series to provide a single mono valve overdrive/filter. This provides a much steeper 24dB per octave slope, and twice the resonance. Plug a mono source into the LEFT input. The output is presented to both the LEFT and RIGHT output connectors.

Rear Panel Connectors

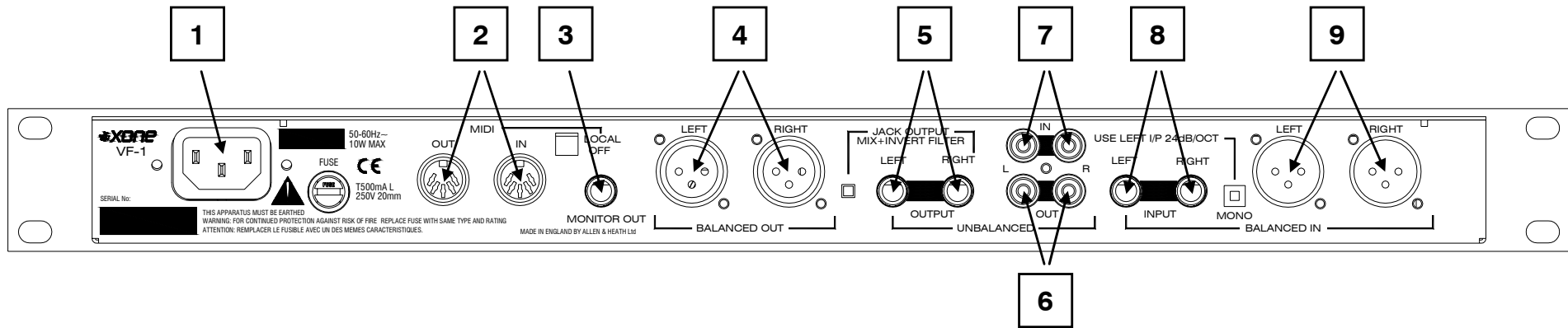

1 AC Mains Input and Fuse

Plug in the IEC mains lead with moulded plug suitable for the local mains voltage supply. The internal power supply has a universal input which accepts a mains voltage in the range 100V to 240V AC 50/60Hz. Make sure your local voltage is within this range.



Before plugging in, read the Important Safety Instructions printed at the start of this user guide and the warnings printed on the VF-1 rear panel.

The VF-1 does not have a power on/off switch. Switch on the mains supply to power the unit.

2 MIDI Out and MIDI In

5 pin DIN sockets. Connect to MIDI compatible equipment using standard 5 pin DIN (MIDI) leads. Press the Local OFF switch if you are using the MIDI function.

3 Monitor Out

1/4" TRS jack output. Tip = left, ring = right, sleeve = ground. Connect to an external console or speaker monitoring system, or plug in high impedance (>70 ohms) headphones. This lets you preview the effect of the filter even when it is bypassed.

4 Left and Right XLR Outputs

Electronically balanced, wired pin 2 hot (+), pin 3 cold (-) and pin 1 ground. Nominal output level is +4dBu with a massive +22dB headroom up to a maximum +26dBu drive. The XLR output is designed to operate with professional balanced equipment such as speaker processors, mixing consoles and amplifiers.

5 Left and Right TRS Jack Outputs

These alternative main outputs are impedance balanced meaning they provide the benefit of cable interference rejection when connected to balanced equipment inputs. They can also connect to unbalanced equipment without the need for cable adaptors. Nominal output level is 0dBu with +22dBu maximum. The jack outputs provide the switched Mix+Invert function.

6 Left and Right RCA Phono Outputs

Provide a convenient connection to consumer equipment such as domestic amplifiers, recorders and DJ mixers. They are unbalanced with nominal 0dBu level.

Note: You may connect to all the outputs at the same time. Using the three different connector types you can provide a split of the output signal to several different destinations.

7 Left and Right RCA Phono Inputs

VF-1 standard version: Connect stereo line level music sources such as CD, MD, DAT, drum machines, keyboards or other instruments. Do not connect turntables which require RIAA equalisation. Nominal level is 0dBu.

VF-1R (RIAA) version: Only connect turntables which require RIAA equalisation – line level sources will overload the preamp and cause severe distortion. Refer also to page 16 (Grounding).

8 Left and Right TRS Jack Inputs

Balanced, wired tip hot, ring cold, sleeve ground. Nominal level is 0dBu. These provide an alternative input for sources such as mixers and instruments equipped with jack sockets. They can work with balanced or unbalanced sources. For unbalanced sources link the jack ring connection to ground.

9 Left and Right XLR Inputs

Balanced, wired pin 2 hot, pin 3 cold, pin 1 ground. Nominal input level is +4dBu. Use these inputs for connection to professional balanced equipment.

Note: Connect to only one pair of inputs at any time. Do not attempt to mix sources together by plugging into more than one connector type.

Note: Plug into the Left input when operating the **VF-1** in mono mode. In this mode the right input is not used.

Audio Cables

To ensure the high quality performance for which the **VF-1** has been designed, we recommend the use of professional grade cables and connectors. Avoid the use of cheap domestic parts. Ensure all wiring is checked for reliable connection and safety grounding. The diagram below illustrates the more common audio cables used.

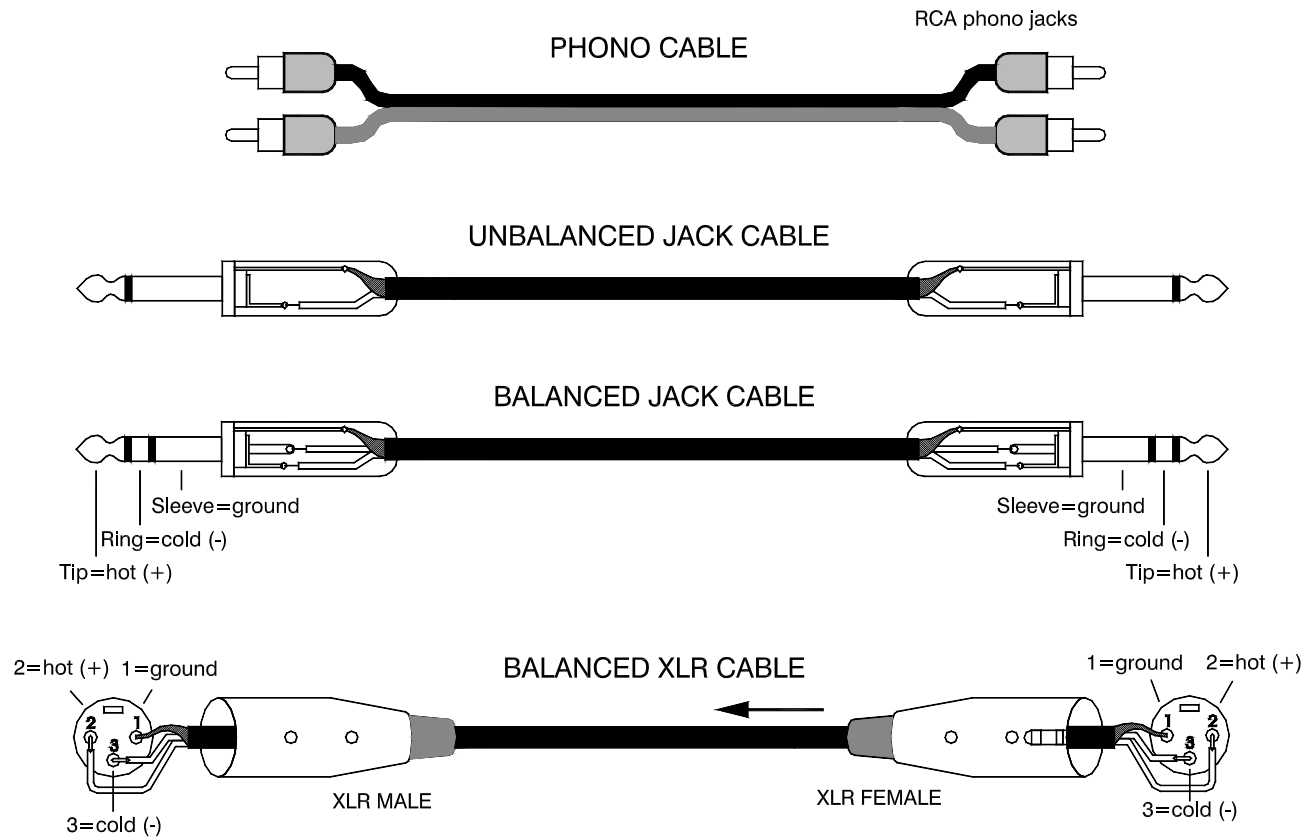

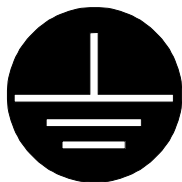

Grounding

The connection to ground (earth) in an audio system is important for two reasons:

- **SAFETY** - To protect the operator from high voltage electric shock, and
- **AUDIO PERFORMANCE** - To minimise the effect of ground loops which result in audible hum and buzz, and to shield the audio signals from interference pickup.



For safety it is important that all equipment grounds are connected to mains ground so that exposed metal parts are prevented from carrying high voltage which can injure or even kill the operator. It is recommended that the system engineer check the continuity of the safety ground from all points in the system including microphone bodies, turntable chassis, equipment cases, and so on.

The same ground is also used to shield audio cables from external interference such as the hum fields associated with power transformers, lighting dimmer buzz, and computer radiation. Problems arise when the signal sees more than one path to mains ground. A 'ground loop' results, causing current to flow between the different ground paths. This condition is usually detected as a mains frequency audible hum or buzz.

When connecting a VF-1R unit (fitted with RIAA preamp option) to a turntable, be sure to connect the turntable ground wire to the chassis ground screw on the VF-1R to prevent hum.

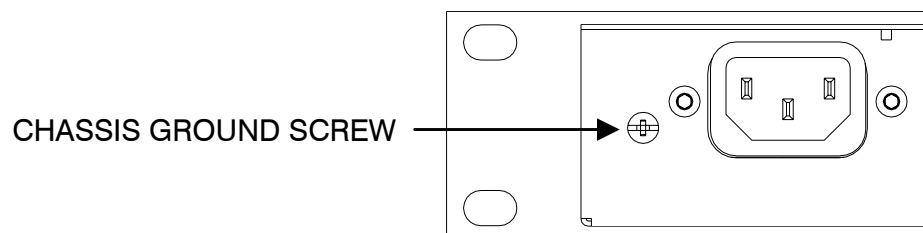

To ensure safe and trouble-free operation we recommend the following:

- **Have your mains system checked by a qualified electrician** If the supply grounding is solid to start with you are less likely to experience problems.
- **Do not remove the ground connection from the power unit mains plug** The console chassis is connected to mains ground through the power cable to ensure your safety. Audio 0V is connected to the console chassis internally.
- **Make sure that turntables are correctly grounded** Chassis ground terminals are provided on the console rear panel to connect to turntable earth straps.
- **Deal with ground loops** Should you experience hum or buzz caused by ground loops, check first that each piece of equipment has its own separate path to ground. If so, operate ground lift switches on connected equipment in accordance with the instruction manuals. Alternatively disconnect the cable screen at one end, usually the destination end. This breaks the offending loop while still maintaining the signal shielding down the length of the cable.
- **Use low impedance** microphones and line level equipment rated at 200 ohms or less to reduce susceptibility to interference. The console outputs are designed to operate at very low impedance to minimise interference problems.
- **Use balanced connections for the microphone and main outputs** as these provide further immunity by cancelling out interference that may be picked up on long cable runs.
- **Route cables to avoid interference** To avoid interference pickup keep audio cables away from mains power units and cables, thyristor dimmer units and computer equipment. Where this cannot be avoided, cross the cables at right angles to minimise interference.
- **Use good quality cables and connectors** and check for correct wiring and reliable solder joints. Use professional grade short cables to connect your turntables to the console RIAA inputs. Allow sufficient cable loop to prevent damage through stretching.

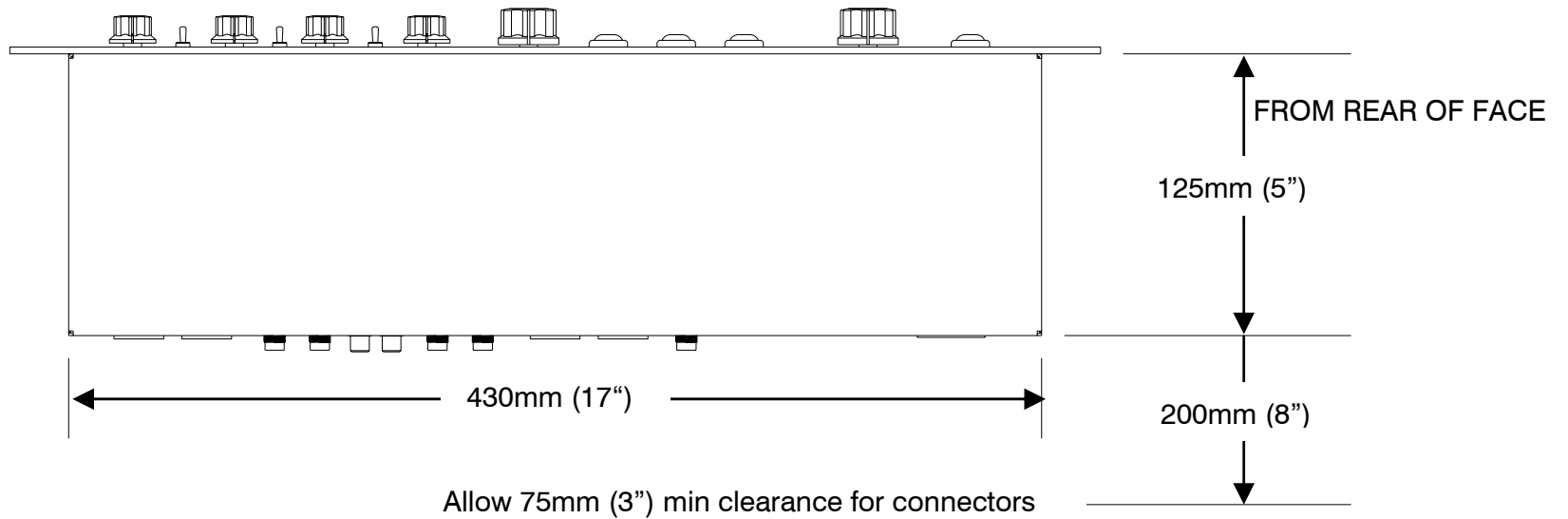
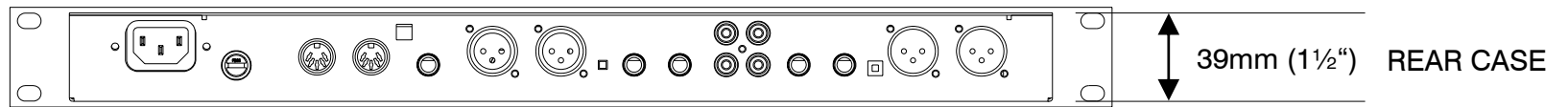
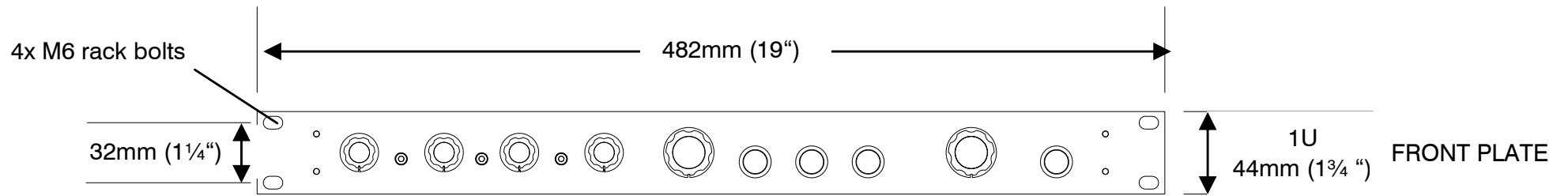

Installing the Unit

19" rack mount The VF-1 fits into a standard 19" rack system taking up 1U height. Use M6 bolts with plastic protective cups. These are usually supplied by the rack manufacturer.

Plinth or furniture mount The VF-1 can be mounted in a custom built plinth or other furniture. Use the cutting template details shown here. The dimensions allow clearance for the cover fixing screws. Secure with suitably long M6 bolts and nuts. Use protective cups to protect the unit's surface.



Allow adequate ventilation around the unit. Do not obstruct the top cover ventilation slots.

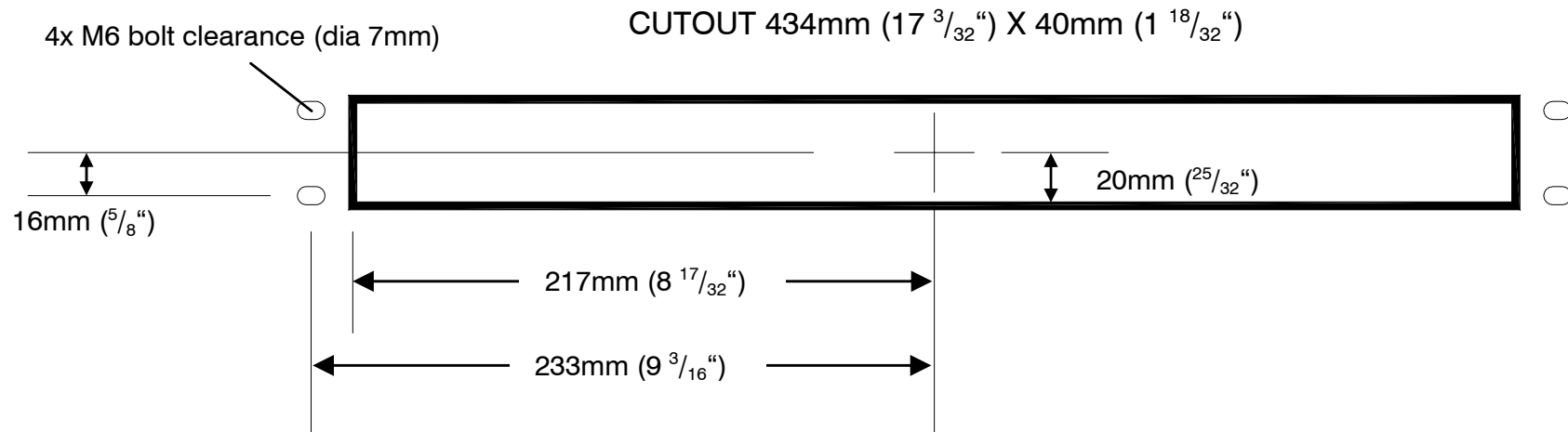



MIDI

MIDI is short for Musical Instrument Digital Interface. It is the popular serial connection standard conceived in the 1980's so that keyboards and other electronic instruments could communicate with each other. Applications now include sound and lighting consoles, computer sequencing, show control and performance effects control. The **XONE VF-1** has MIDI In and Out sockets allowing external control of the filter and synchronization with other MIDI devices.

The **XONE VF-1** MIDI interface provides full in and out external control of the filter type, cut-off frequency and on/off settings. The filter can integrate with MIDI equipped sequencers, effects units, mixers and keyboards to create a new dimension to live performance and recorded sound.

Three additional MIDI In modes can be selected to give maximum flexibility for advanced users. These allow the unit to be controlled in a variety of ways from the controls on the Allen & Heath **XONE:92** DJ mixer or from the notes on a standard MIDI keyboard. The MIDI channel number defaults to 16 but can be easily changed to any channel from 1 to 16.

The following filter parameters can be controlled by MIDI:

Filter cut-off frequency

Hi-pass in/out

Band-pass in/out

Low-pass in/out

Filter on/off

Setting the MIDI Channel Number

The MIDI channel number and mode settings on the **XONE VF-1** are adjusted using power-up menus. These are accessed by holding down buttons while applying power to the unit. We advise that you turn the amplifiers off and remove the **VF-1** from the audio signal path while changing MIDI settings to avoid unexpected sounds being generated.

1. Hold down the Hi-pass filter button whilst switching on the power to the **VF-1**. All three of the filter type indicators will light.
2. Release the Hi-pass button. The current MIDI channel number will be displayed encoded on the front panel lights (see table).
3. Press the High-pass button repeatedly to cycle through MIDI channels 1 to 16.
4. To store the selected MIDI channel and continue with normal operation press the Filter ON button.

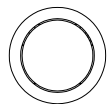

HI-PASS

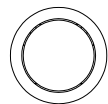

BAND-PASS

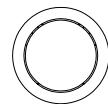

LOW-PASS

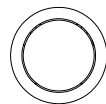

FILTER ON

X = light off, O = light on

MIDI Ch	Hi-pass	Band-pass	Low-pass	Filter ON
1	X	X	X	X
2	X	X	X	O
3	X	X	O	X
4	X	X	O	O
5	X	O	X	X
6	X	O	X	O
7	X	O	O	X
8	X	O	O	O
9	O	X	X	X
10	O	X	X	O
11	O	X	O	X
12	O	X	O	O
13	O	O	X	X
14	O	O	X	O
15	O	O	O	X
16	O	O	O	O

Using MIDI to Link VF-1 Units

For more dramatic effects two **XONE VF-1** units can be connected together to make a stereo 24dB/Octave system. Connect a MIDI cable from the MIDI Out of the first **VF-1** (master) to the MIDI In of the second (slave). Press in the rear-panel Local Off switch on the slave to allow it to respond to MIDI In messages. The slave **VF-1** will now follow the filter type, cut-off frequency and filter on/off settings of the master. Switch both the master and the slave to MONO using the rear-panel switch on each. Now route one channel through the master and the second channel through the slave.

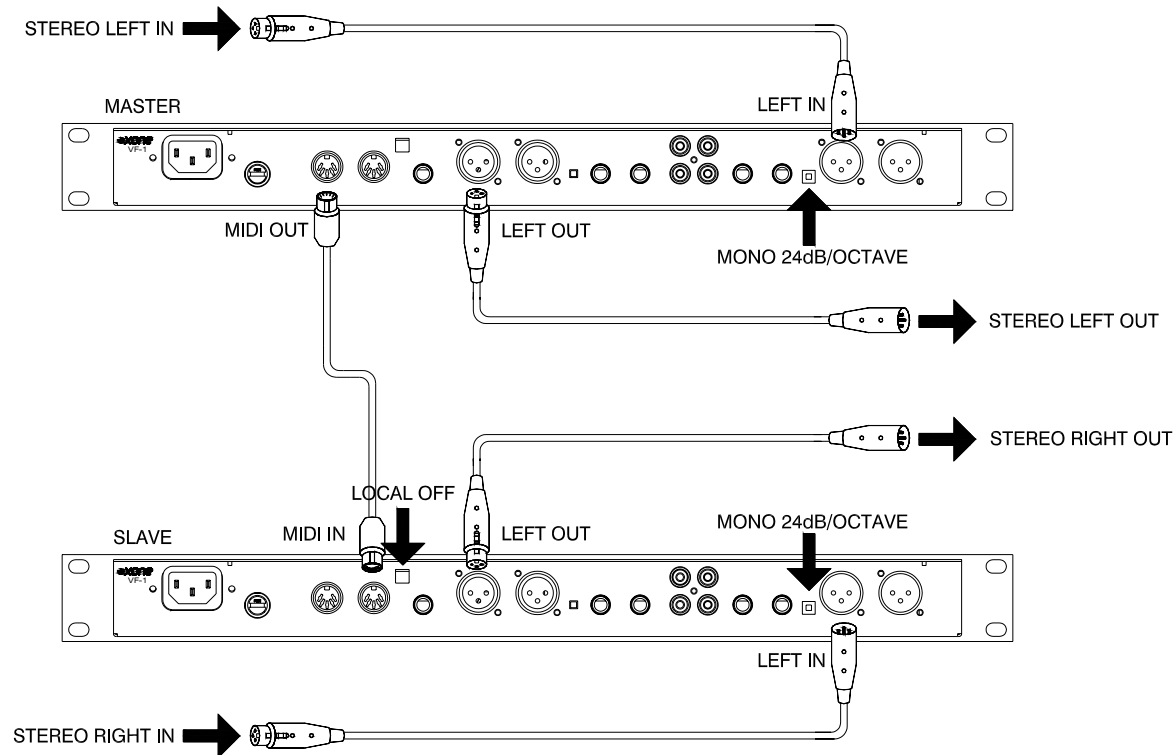

Using MIDI to Connect a Sequencer or Effects Controller

By connecting the **XONE VF-1** to an external sequencer you can record and replay filter sweeps and settings changes. Connect the MIDI Out from the **VF-1** to the MIDI In of a sequencer and the MIDI In on the **VF-1** to the MIDI Out of the sequencer. Configure MIDI Thru on the sequencer to echo MIDI Input to MIDI output. Now make sure that the Local OFF switch on the rear-panel is selected so that the **VF-1** will respond to MIDI In messages.

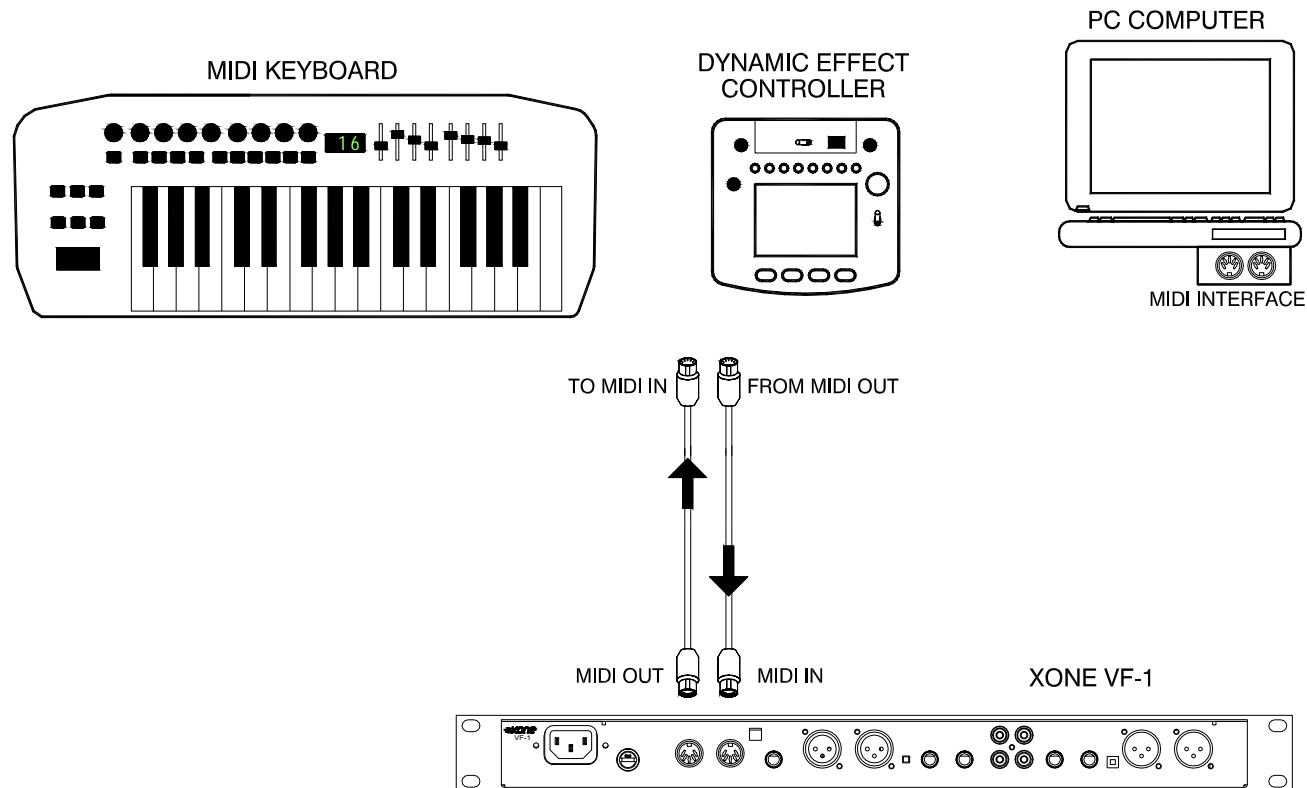

MIDI Control Codes

The **XONE VF-1** has a standard set of MIDI control assignments. This is always used for MIDI output and input and cannot be disabled. Three additional MIDI In modes can be enabled to allow for advanced applications using additional MIDI messages.

Standard MIDI Assignments

These are used for both MIDI Input and output. To control the filter using MIDI make sure the **VF-1** rear panel Local OFF switch is pressed in. For all parameters, except VCF Frequency, MIDI outputs the current status of the filter regardless of the setting of the Local OFF switch or whether the filter was changed using the front panel switches or MIDI input. For the VCF Frequency, MIDI outputs the current position of the front-panel control, not the actual filter cut-off frequency. This means that the VCF Frequency MIDI output follows the front panel control whilst the **VF-1** filter follows the MIDI input.

XONE VF-1 Function	Controller Code	Controller Name
High-Pass Filter	CC80	GP Button 1
Band-Pass Filter	CC81	GP Button 2
Low-Pass Filter	CC82	GP Button 3
Filter On/Off	CC83	GP Button 4
VCF Frequency	CC74	Brightness

Mode 1 : **XONE:92 Controller Mode**

Connect the MIDI output of an Allen & Heath **XONE:92** DJ Mixer to the MIDI input of the **VF-1** and enable this option. The rear-panel Local OFF switch should be pressed in to allow the **VF-1** to receive MIDI messages. It is also important to set the MIDI channel of the **VF-1** to the same channel used by the **XONE:92**. See your **XONE:92** users guide for information on its MIDI channel assignment. With this mode enabled some of the **XONE:92** controls can now be used to alter the filter settings on the **VF-1**.

Mode 2 : **Keyboard Tracking Mode**

With this mode enabled, the VCF Frequency will follow the pitch of key presses on a MIDI keyboard connected to the **VF-1** MIDI Input. For this to work correctly the **VF-1** and the keyboard must be set to use the same MIDI Channel. With the band-pass filter selected its centre frequency will be approximately 1 octave above the corresponding note on the keyboard.

Mode 3 : **Keyboard Mute Mode**

When enabled, this mode causes a key press on an a connected MIDI keyboard to switch the filter type to the last setting used. On releasing all keys on the keyboard the sound will be muted (by deselecting all filter types). By combining MODE 1 and MODE 2 the **VF-1** filter will pick out only the frequencies around the note you press on the keyboard. Try experimenting with this on music or synthesiser sounds to get an idea of the range of effects possible.

XONE VF-1 Function	Controller Code	XONE:92 Control
Filter Type Selection	CC13	VCF 2 FREQ
Filter On/Off	CC92	Crossfader movement
VCF Frequency	CC12	VCF 1 FREQ

Selecting the MIDI In Modes

1. Hold down the Filter ON button whilst switching on the power to the **XONE VF-1**. All three of the Filter Type indicators will light.
2. Release the Filter ON button. The current mode settings will be displayed on the three Filter Type indicator lights (see table). Press the Filter Type buttons to toggle each mode on or off.
3. To store the mode settings and return to normal operation press the Filter ON button again.

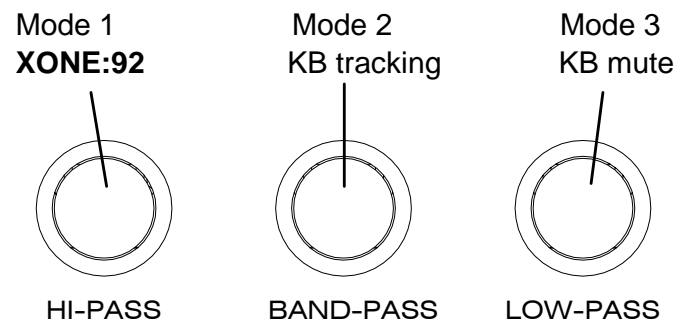

XONE VF-1 MIDI Implementation Chart

O = Available X = Not used

Function	Transmitted	Received	Remarks
Basic Channel			
Default	16	16	Transmits and receives on the same MIDI channel
Option	1-16	1-16	
Mode			
Default	X	X	
Messages	X	X	
Altered	X	X	
Note Number	X	O	Keyboard tracking mode
Velocity			
Note ON	X	O	Keyboard mute mode
Note OFF	X	O	
Aftertouch			
Keys	X	X	
Channel	X	X	
Pitch Bend	X	X	

Function	Transmitted	Received	Remarks
Control Change			
74	O	O	
80	O	O	
81	O	O	
82	O	O	
83	O	O	
12	X	O	XONE:92 controller mode
13	X	O	
92	X	O	
Program Change	X	X	
System Exclusive	X	X	
System Common			
Song Position	X	X	
Song Select	X	X	
Tune Request	X	X	
System Real Time			
Clock	X	X	
Commands	X	X	
Aux Messages			
Local On/Off	X	X	
All Notes Off	X	X	
Active Sensing	X	X	
System Reset	X	X	

Technical Specification

Operating Levels

XLR	+4dBu	Headroom +22dB
Jack	0dBu	Headroom +22dB
RCA	0dBu	Headroom +22dB
RIAA Preamp (VF-1R version)		
	3-140mV	47K/330pF
Maximum output	XLR +26dBu	
	TRS jack +22dBu	

Frequency Response 10Hz-30KHz

Line to Main output +0/-0.5dB (Filter OFF)

Distortion at 1KHz +4dBu out

THD + Noise <0.002% (Filter OFF)

Noise Performance rms 22Hz-22KHz

Residual output noise measured at XLR output

Filter off <-100dBu (104dB S/N)

Filter on <-85dBu (89dB S/N)

Connection Impedances

Line Inputs	>9K ohms
Outputs	<50 ohms

Filter

Type	VCF, stereo 12dB/octave or mono 24dB/octave selectable hi-pass, band-pass, lo-pass, notch, all-pass
Sweep range	20Hz-20KHz
Control	Manual, envelope follower, LFO, MIDI
Resonance	Variable, Automatic resonance control

Valve Overdrive

Type	ECC82 (12AU7)
Control	Manual, envelope follower

System

Power supply	Internal Universal Input
Power consumption	14W Max, 7W nominal

XONE VF-1 BLOCK DIAGRAM

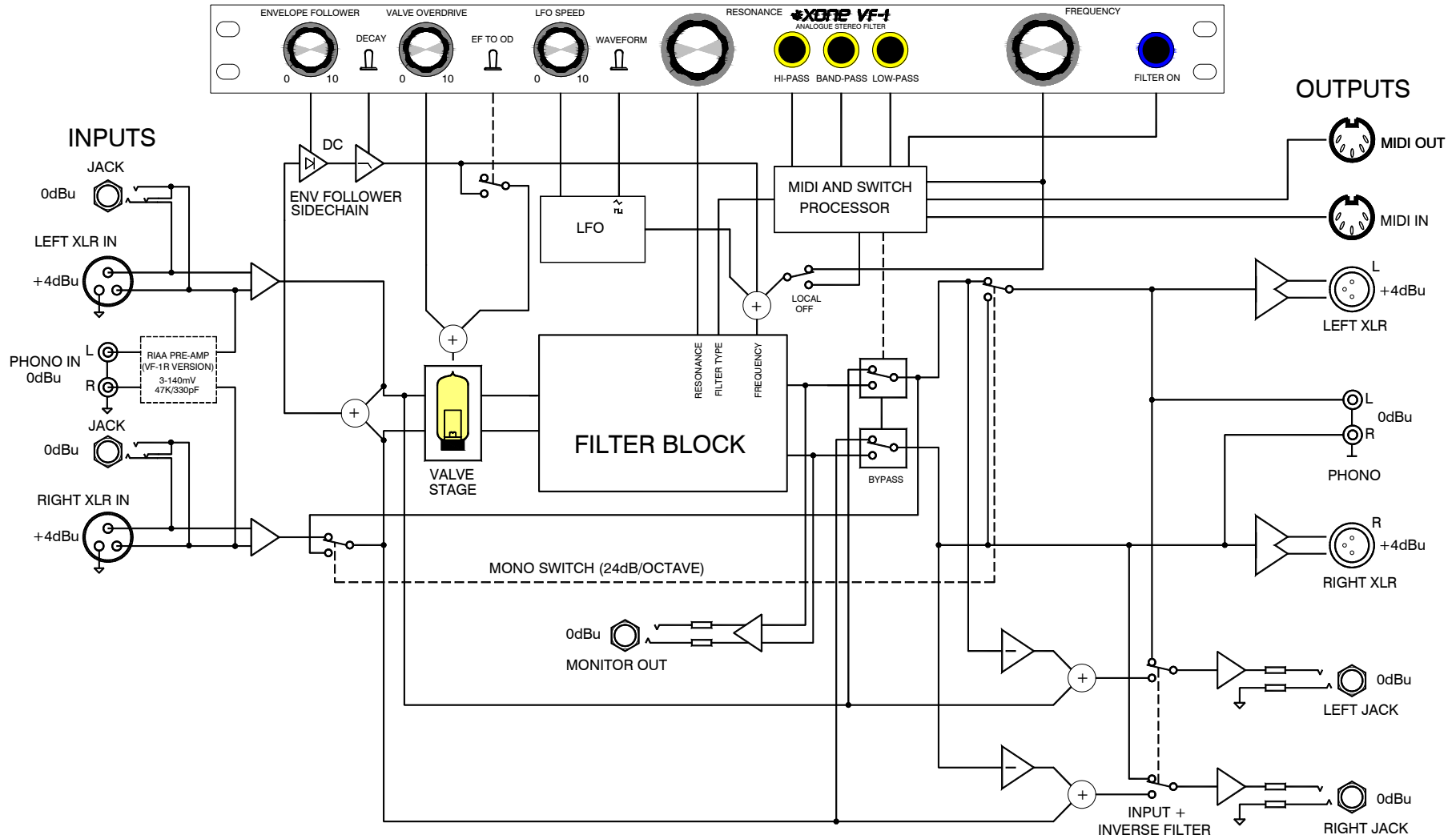

User Notes:

